

# Reverse Call for Visitor Monitoring Service



***AddPac***

**AddPac Technology**

Sales and Marketing

# Contents

- Network Diagram
  - Integrated Door Access Control and Call Control
  - Reverse Call Door Open
- Direct Call Configuration
  - Smart Web – Reverse Call Door Open
- DACS System Message Flow
  - Call Flow between Attendant and IP Video Door Phone

# Network Diagram

## Integrated Door Access Control and Call Control

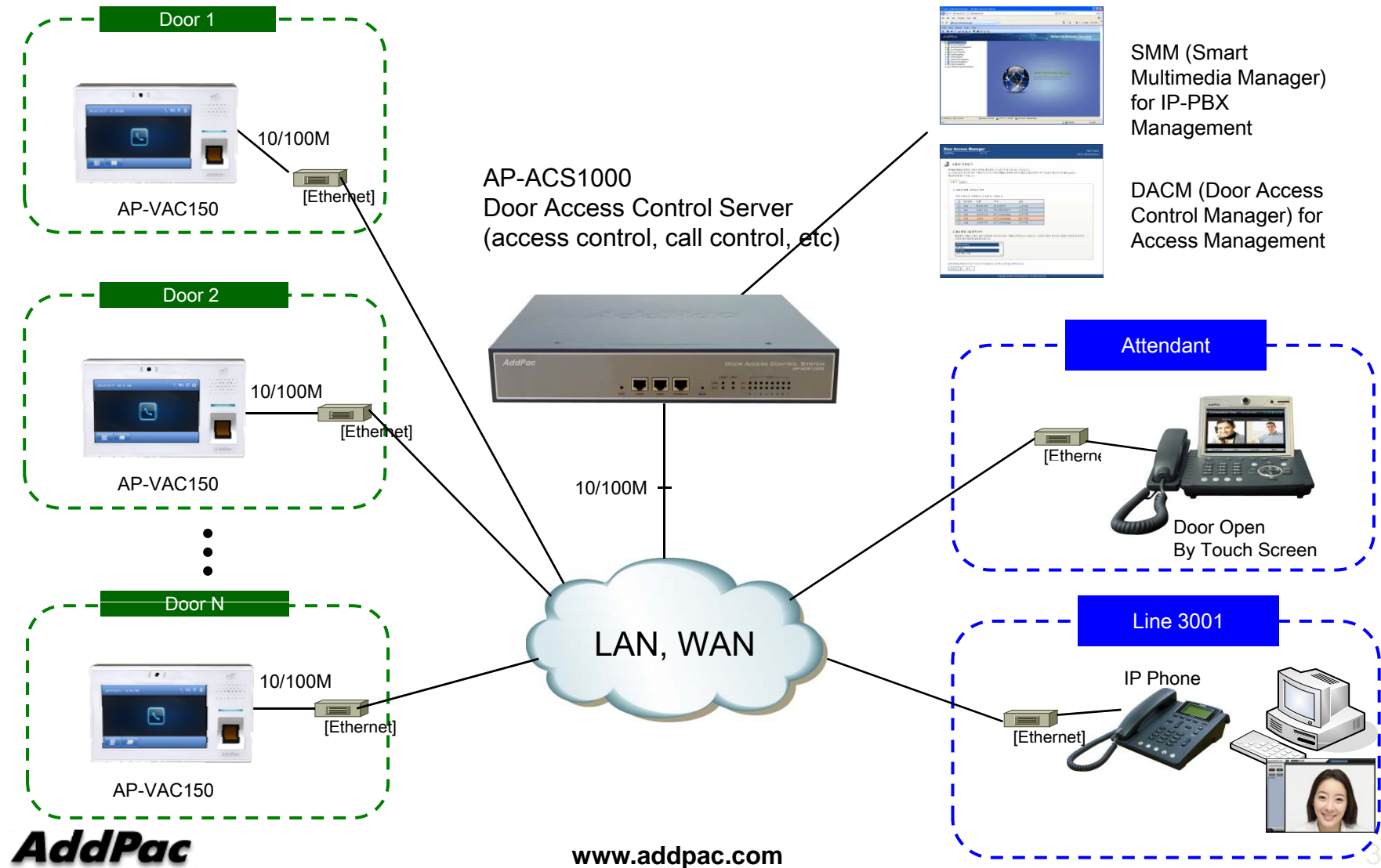

# Network Diagram

## Reverse Call Door Open

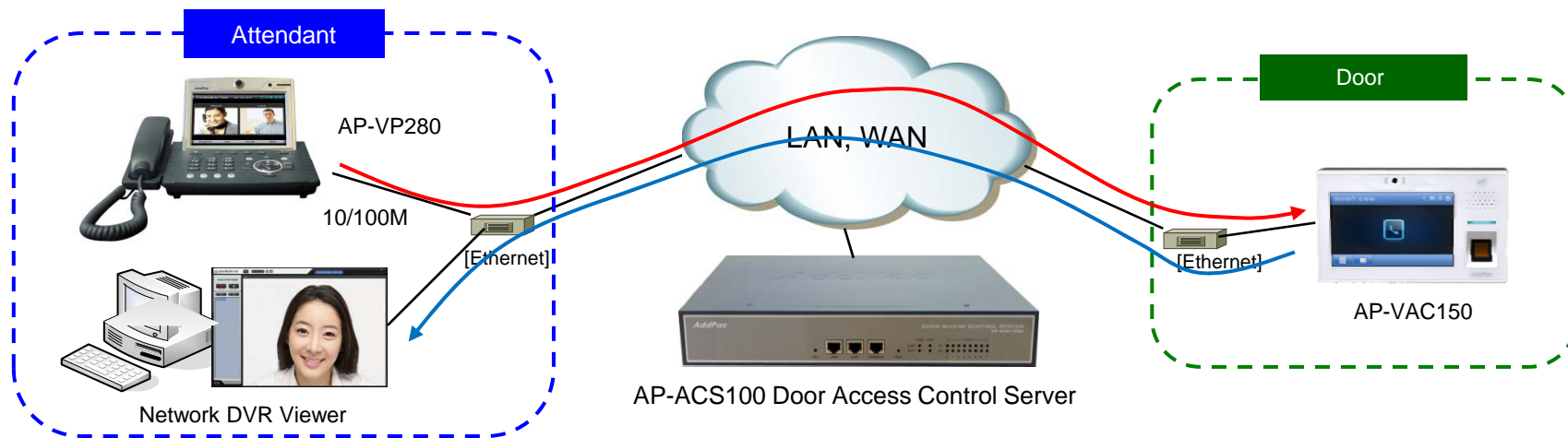

- Door Open Control function when an attendant makes a call to an external IP Video Door Phone
  - Reverse Call Door Open Control
  - Reverse Call Door Open Enable/Disable
  - Direct Auto Answer

# Indoor Open Control

## Smart Web – Reverse Call Door Open

The screenshot displays the Smart Web Manager interface for configuring Indoor Open Control. The left sidebar shows a navigation menu with categories: System, Call & Media, Door Access Control, and Miscellaneous. The 'Indoor Open Control' option is selected under Door Access Control. The main content area is titled 'Indoor Open Control' and contains several configuration sections:

- Feature Code:** A text input field containing '1' with a note 'using 0-9, #, \*'.
- Door Close Time:** A text input field containing '2' with a note 'default 2 sec, 1-180 sec'.
- Authentication:** A section with three checkboxes: Password, RF-Card, and User-Call.
- Dual-Authentication:** A section with one checkbox: RF-Card + Password.
- Received Call Door Open:** A section with two radio buttons: Enable (selected) and Disable. This section is highlighted with a red dashed box.
- Direct Door Open:** A section with an 'Execute' button.

On the right side, there are two panels: 'Information' and 'Description'. The 'Information' panel shows system details like 'AddPac Technology', 'Model: VAC50\_G2', and registration status. The 'Description' panel states 'Open/Close the door remotely.'.

**Reverse Call Door Open**  
Settings for Indoor Open, in receiving a call  
Enable / Disable  
Direct Auto Answer is applied by checking Enable Button.

# DACS System Message Flow

Call Flow between Attendant and IP Video Door Phone

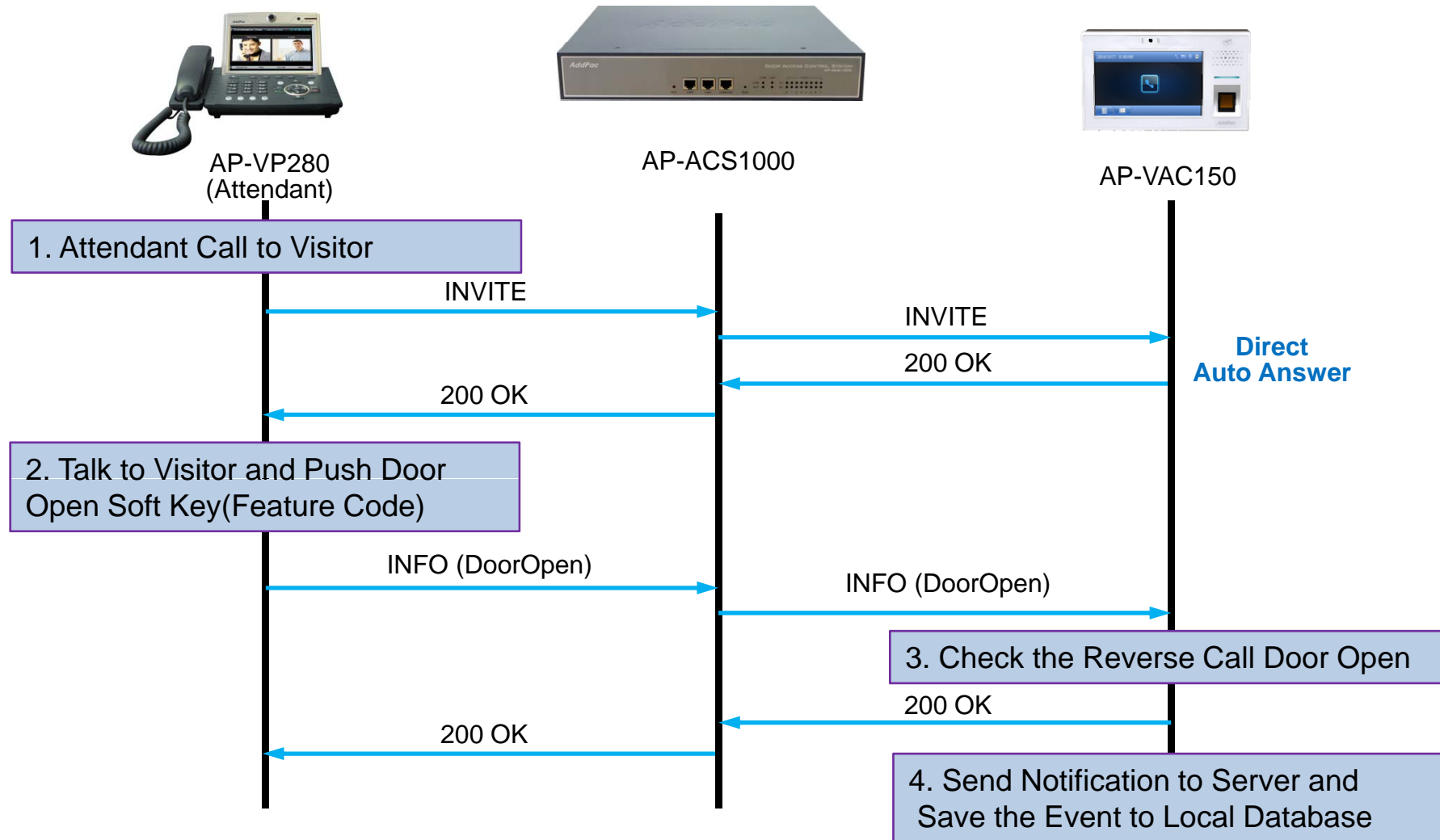



# Thank you!

**AddPac Technology Co., Ltd.**  
Sales and Marketing

Phone +82.2.568.3848 (KOREA)

FAX +82.2.568.3847 (KOREA)

E-mail [sales@addpac.com](mailto:sales@addpac.com)