

# Reverse Call for Visitor Monitoring Service



***AddPac***

**AddPac Technology**

Sales and Marketing

# Contents

- Network Diagram
  - Integrated Door Access Control and Call Control
  - Legacy PBX Environment
  - Legacy IP-PBX Environment
  - Reverse Call Door Open
- Direct Call Configuration
  - Smart Web – Reverse Call Door Open
- DACS System Message Flow
  - Call Flow between Attendant and IP Video Door Phone



# Network Diagram

## Integrated Door Access Control and Call Control

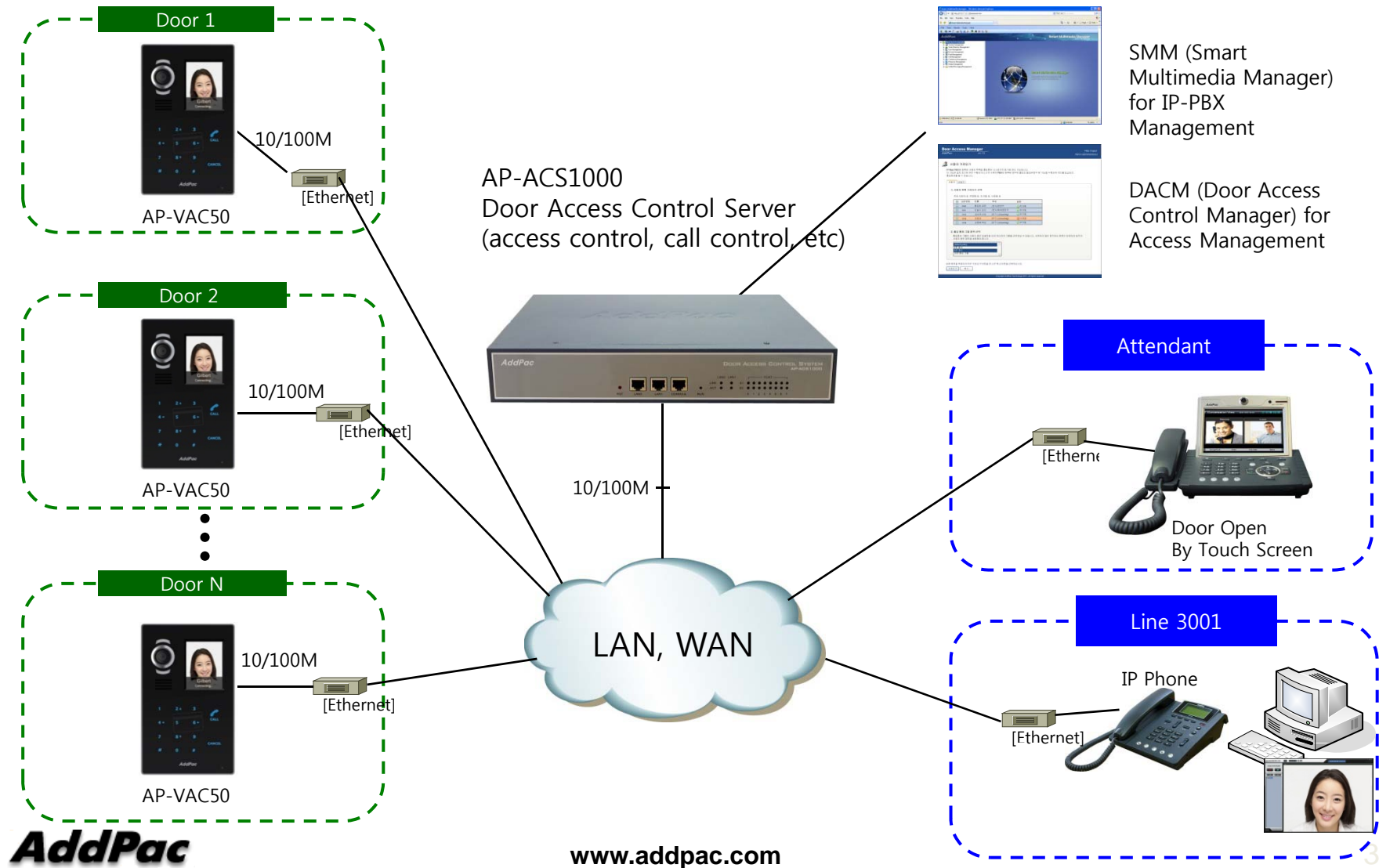

# Network Diagram

## Legacy PBX Environment

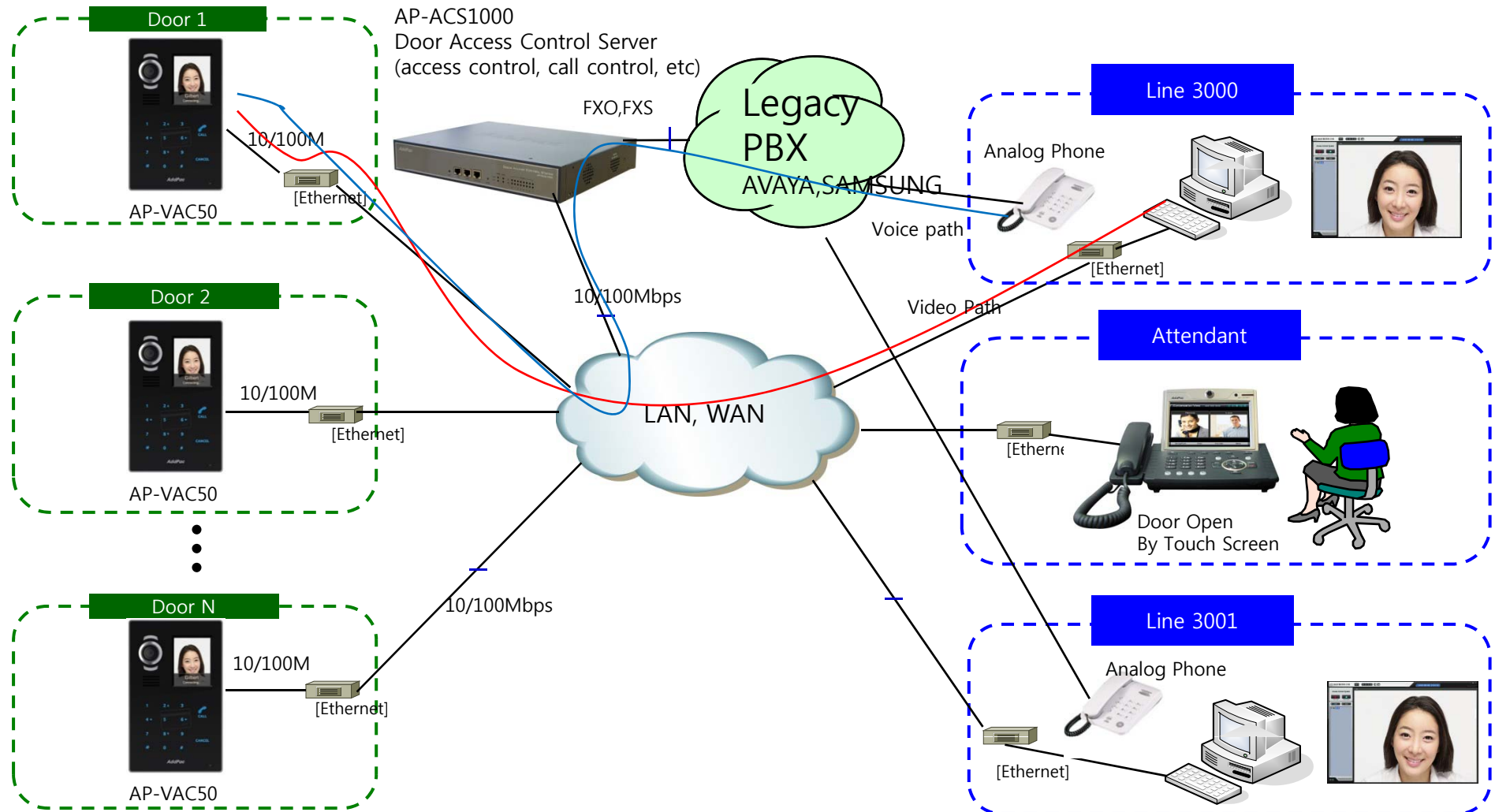

# Network Diagram

## Legacy IP-PBX Environment

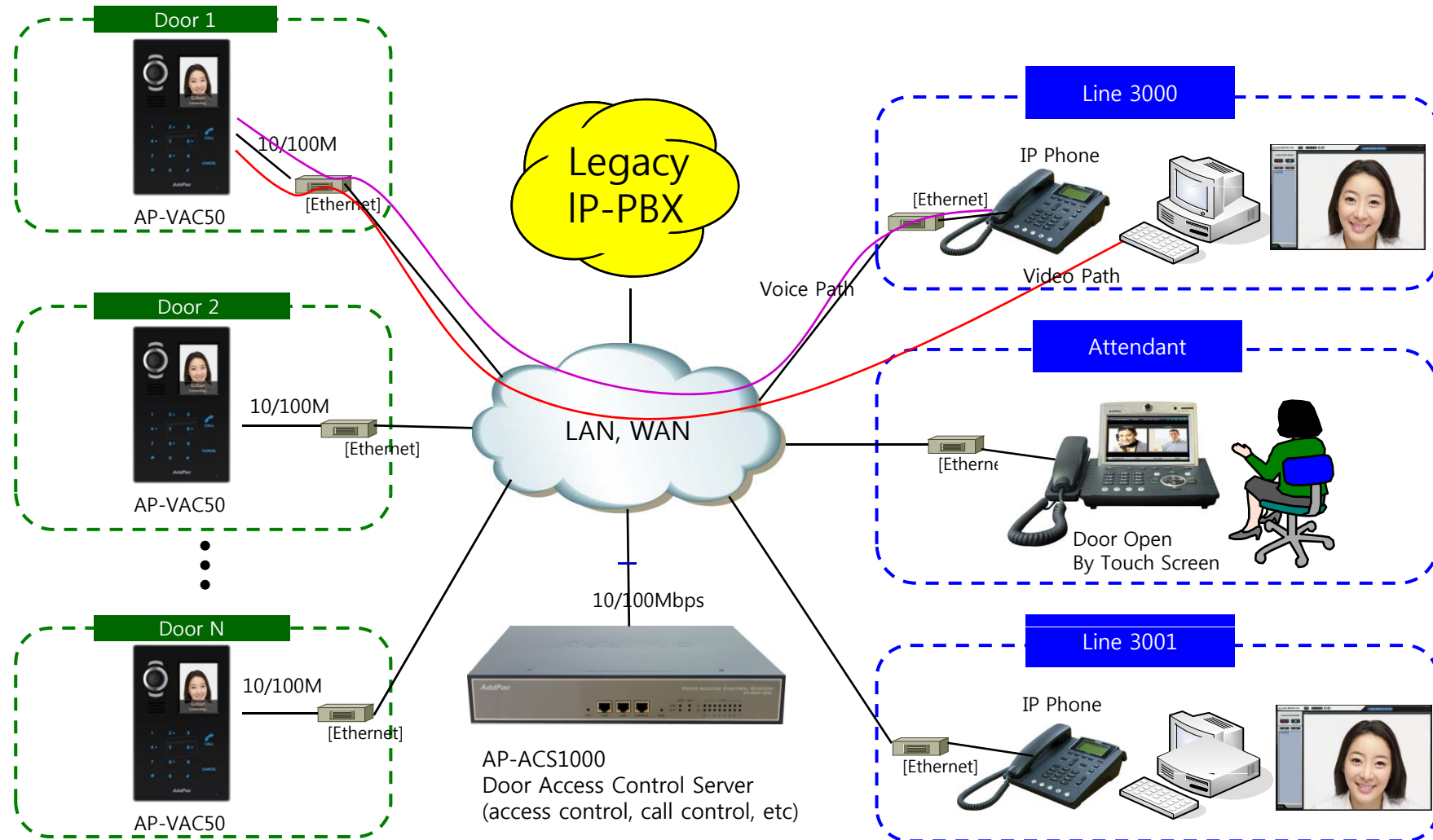

# Network Diagram

## Reverse Call Door Open

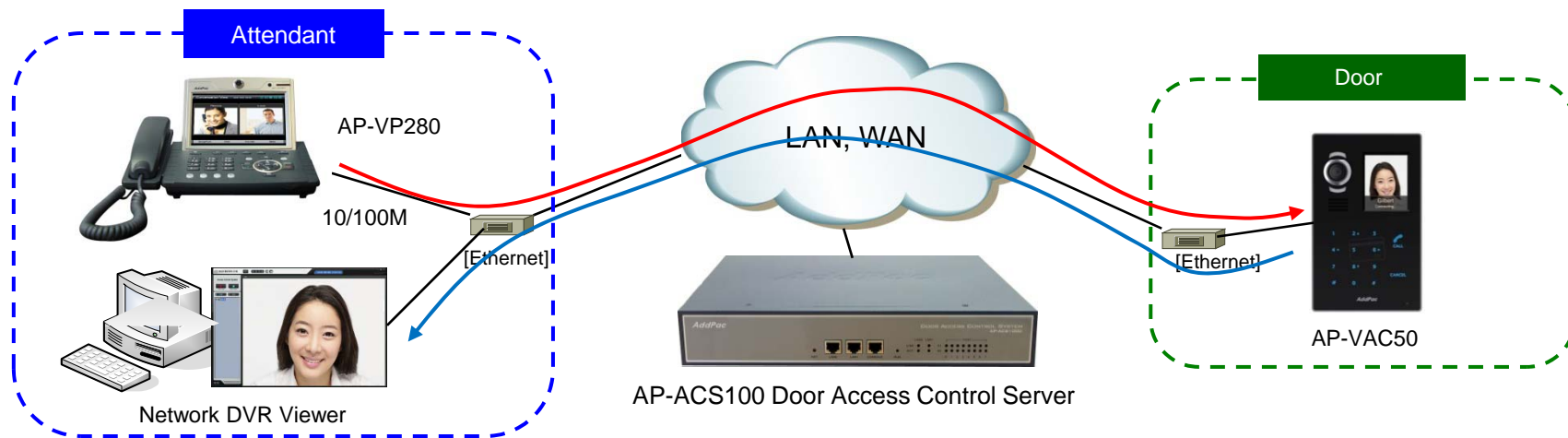

- Door Open Control function when an attendant makes a call to an external IP Video Door Phone
  - Reverse Call Door Open Control
  - Reverse Call Door Open Enable/Disable
  - Direct Auto Answer

# Indoor Open Control

## Smart Web – Reverse Call Door Open

The screenshot displays the 'Smart Web Manager' interface for 'Indoor Open Control'. The left sidebar contains a navigation menu with categories: System, Call & Media, Door Access Control, and Miscellaneous. The 'Indoor Open Control' option is selected under 'Door Access Control'. The main content area shows three configuration sections: 1. Feature Code: '1' (using 0-9, #, \*). 2. Door Close Time: '2' (default 2 sec, 1-180 sec). 3. Authentication: Password, RF-Card, User-Call (all unchecked). 4. Dual-Authentication: RF-Card + Password (unchecked). 5. Received Call Door Open: Radio buttons for 'Enable' (selected) and 'Disable'. 6. Direct Door Open: 'Execute' button. Each section has an 'Apply' button. A red dashed box highlights the 'Received Call Door Open' section. A yellow callout box at the bottom right explains the 'Reverse Call Door Open' settings.

**Reverse Call Door Open**  
Settings for Indoor Open, in receiving a call  
Enable / Disable  
Direct Auto Answer is applied by checking Enable Button.

# DACS System Message Flow

Call Flow between Attendant and IP Video Door Phone

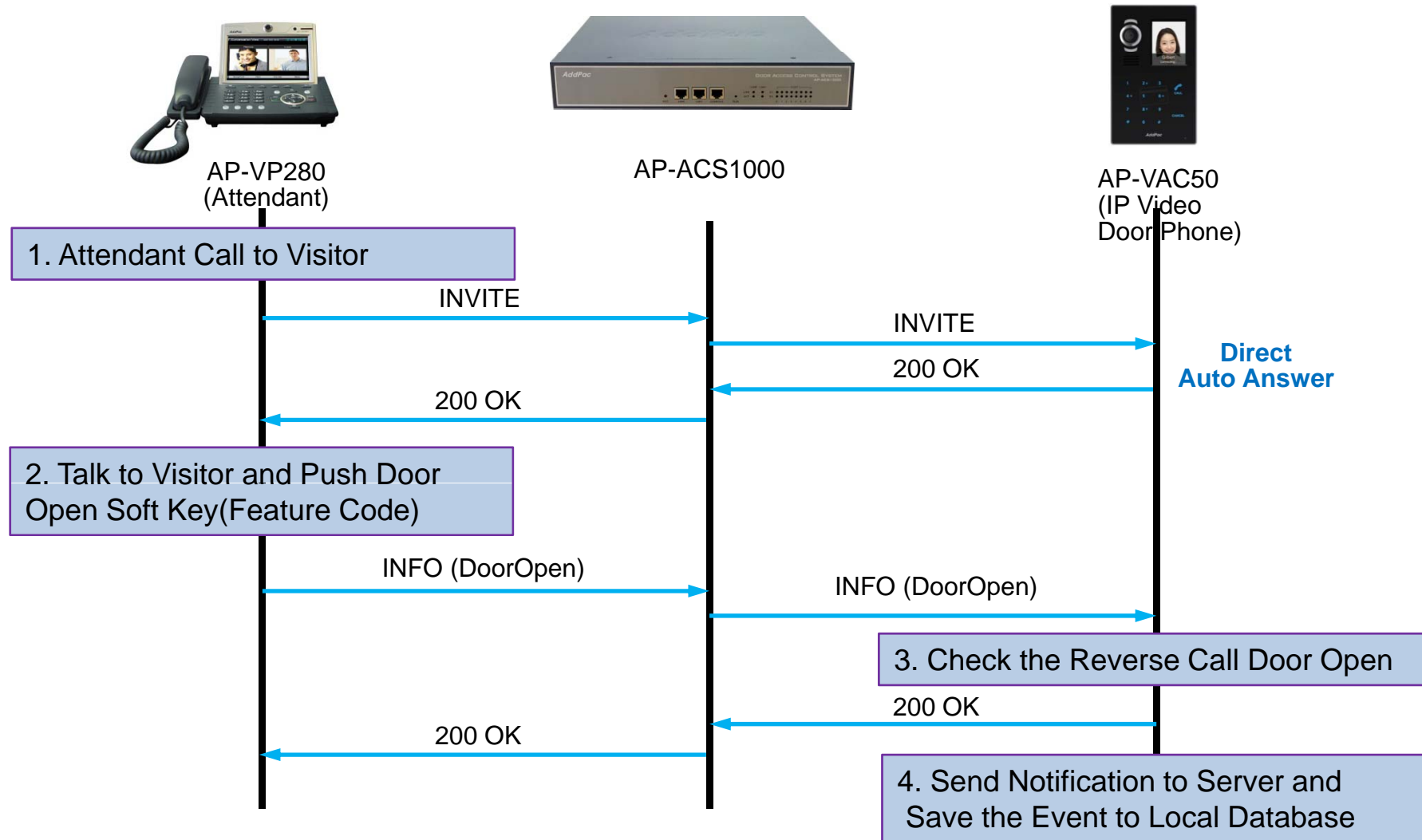





# Thank you!

**AddPac Technology Co., Ltd.**  
Sales and Marketing

Phone +82.2.568.3848 (KOREA)

FAX +82.2.568.3847 (KOREA)

E-mail [sales@addpac.com](mailto:sales@addpac.com)