

AP-GS3000

Multi-Port GSM Gateway

High Performance GSM Gateway Solution

Preliminary Product Overview

(Without notice, following described technical spec. can be changed)



AddPac

AddPac Technology

Sales and Marketing

www.addpac.com

Contents

AP-GS3000 Multi-Port GSM Gateway

- ? Product Overview
- ? Hardware Specification
- ? GSM Module Specification
- ? APOS Technology
- ? VoIP (Voice over IP) service
- ? Advanced QoS Features
- ? Network Protocols
- ? Network Management
- ? Smart Web Management
- ? Security Management
- ? Application Service
- ? Ordering Information



Product Overview

AP-GS3000 Multi-Port GSM Gateway

Main Features

- ? Ten(10) Module Slots for 4-Port GSM Module, 8FXS/8FXO Analog Interface (Up to 32-Port GSM, Digital E1/T1 Module, CPU Module)
- ? H.323/SIP/MGCP Triple Concurrent Stack Embedded
- ? High Performance RISC & Programmable DSP Architecture
- ? G.711/G.726/G.723/G.729, T.38 Fax , VAD, etc
- ? Powerful Network Protocols (PPPoE, DHCP, Static Routing, etc)
- ? Two(2)10/100Mbps Fast Ethernet
- ? One(1) RS-232C Port for Command Line Interface
- ? Firmware Upgradeable Architecture
- ? VPMS (VoIP Plug&Play Management System) & NMS for Large Scale Deployment
- ? Advanced Voice QoS Mechanism
- ? Rack Mountable Chassis with Internal Power Supply

Product Highlights

AP-GS3000 Multi-Port GSM Gateway

Powerful GSM Gateway

State-of-art Signaling
H.323, SIP, MGCP
Concurrent Triple Stack

Rack Mountable Chassis

Ten(10) Module Slot
4-Port GSM Module,
8-Port FXS Module,
8-Port FXO Module,
Digital E1/T1 Module

High Performance RISC CPU
+ Programmable DSP

Excellent Voice Quality
G.729/G.723/G726/G711

Broadband IP Networking
With Two(2) 10/100Mbps
Fast Ethernet

APOS? Technology
Firmware Upgradeable Architecture

VPMS, NMS Large Scale VoIP
Gateway Management Support

Powerful Network Protocol
Support

Powerful Trouble Shooting &
Debugging Feature Support

Advanced Voice
Traffic QoS Mechanism

AddPac

www.addpac.com

APOS Technology

AP-GS3000 Multi-Port GSM Gateway

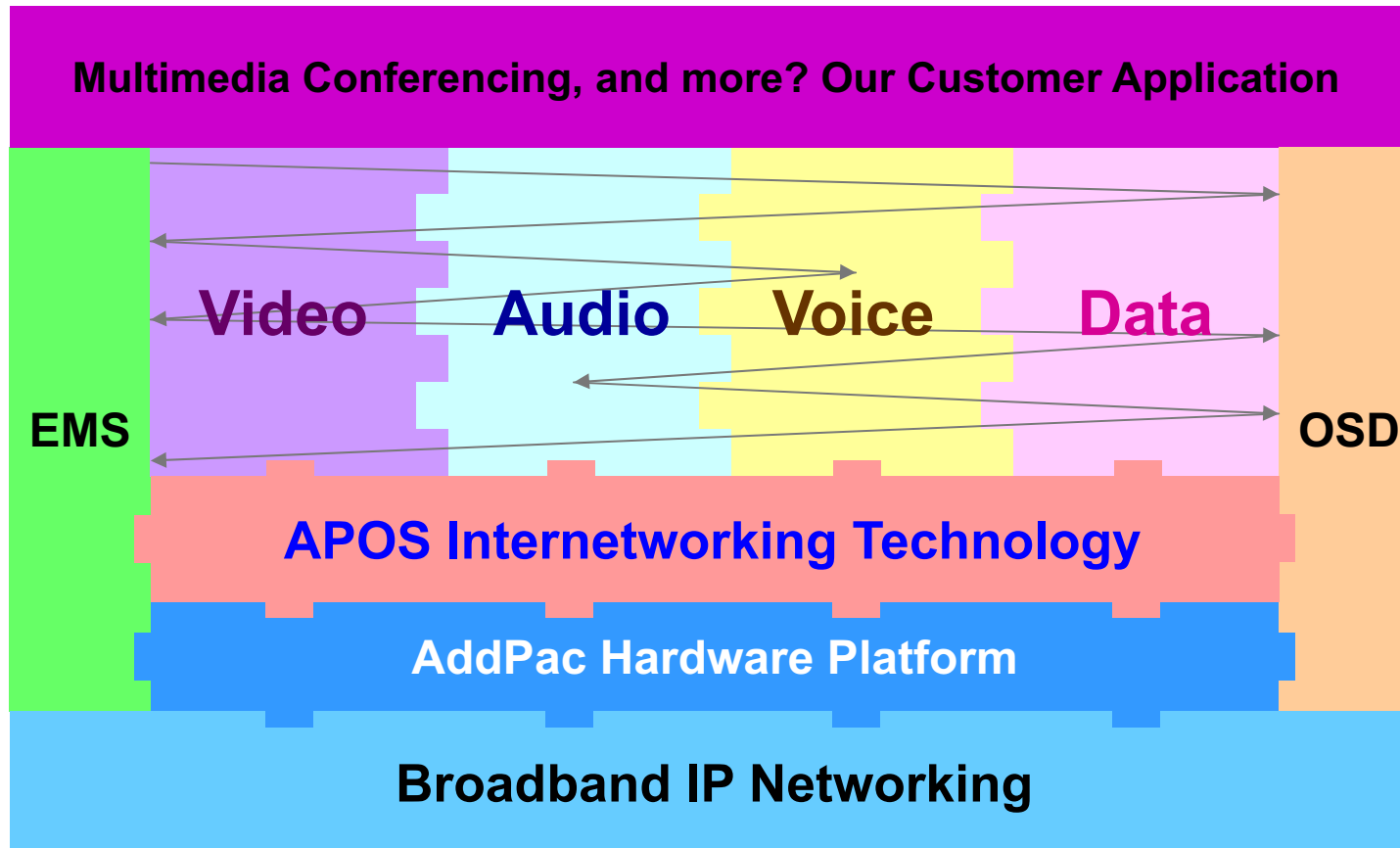

? APOS : AddPac Internetworking Operating System
? OSD : On- Screen Display
? EMS : Element Management System

Hardware Specification

AP-GS3000 Multi-Port GSM Gateway

RISC
CPU

High-end
DSP

- ? RISC Microprocessor Computing Power
- ? Ten(10) Module Slot for GSM, Analog /Digital VoIP Interface, CPU board
- ? 4-Port GSM Module(AP-N1-GSM4)
 - ? 4-Port SIM Card Slot
 - ? One(1) GSM Antenna Interface (Internal 4 Channel Combiner)
- Hot-Swap
- ? VoIP Interface Module (Hot-Swap)
 - ? 8-Port FXS Module (AP-N1-FXS8)
 - ? 8-Port FXO Module (AP-N1-FXO8)
 - ? Digital E1/T1 Module (AP-N1-E1)
- ? Network Interface
 - Two(2) 10/100Mbps Fast Ethernet (RJ45)
- ? RS232C Console Interface for CLI
- ? Run LED, LAN LED, Port LEDs
- ? Internal Power Supply



Hardware Specification

AP-GS3000 Multi-Port GSM Gateway

RISC
CPU

High-end
DSP

Hardware Specifications

AP-GS3000 GSM Gateway	Basic Specifications
Voice Interface	Ten(10) Module Slots including CPU Module
	AP-N1-GSM4, AP-N1-FXS8, AP-N1-FXO8, AP-N1-FXS4O4, AP-N1-E1
Ethernet Interface	2-Ports 10/100Mbps Ethernet Interface(RJ-45)
Flash Memory	512Mbyte NAND Flash Memory
Base Memory	128Mbyte High-speed DDR2
Power Requirement	Power Supply / VAC 110~220V, 50/60Hz, 5V 30A
Operating Temperature	0℃ ~ 45℃ (32℉ ~ 122℉)
Storage Temperature	-40℃ ~ 85℃ (-40℉ ~ 185℉)
Relative Humidity	5% ~ 95% (Non-condensing)
Dimensions	W× D× H (488mm x 300mm x 177mm)
Weight(kg)	9.6Kg

Hardware Specification

AP-GS3000 Multi-Port GSM Gateway

RISC
CPU

High-end
DSP

Hardware Specification

Front Side View

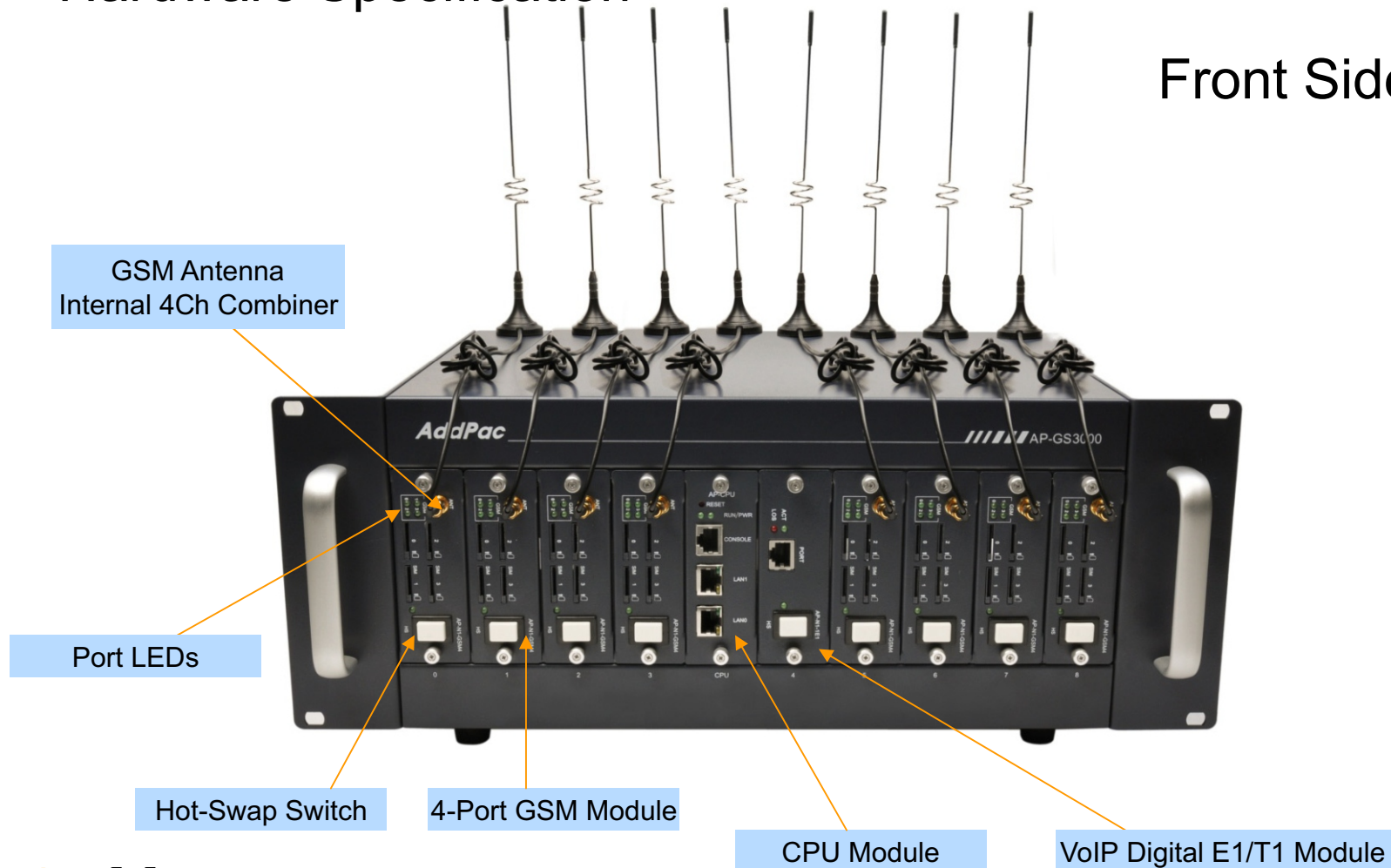

AddPac

www.addpac.com

GSM Gateway

AP-GS3000 Multi-Port GSM Gateway

Hardware Specification

Back Side View

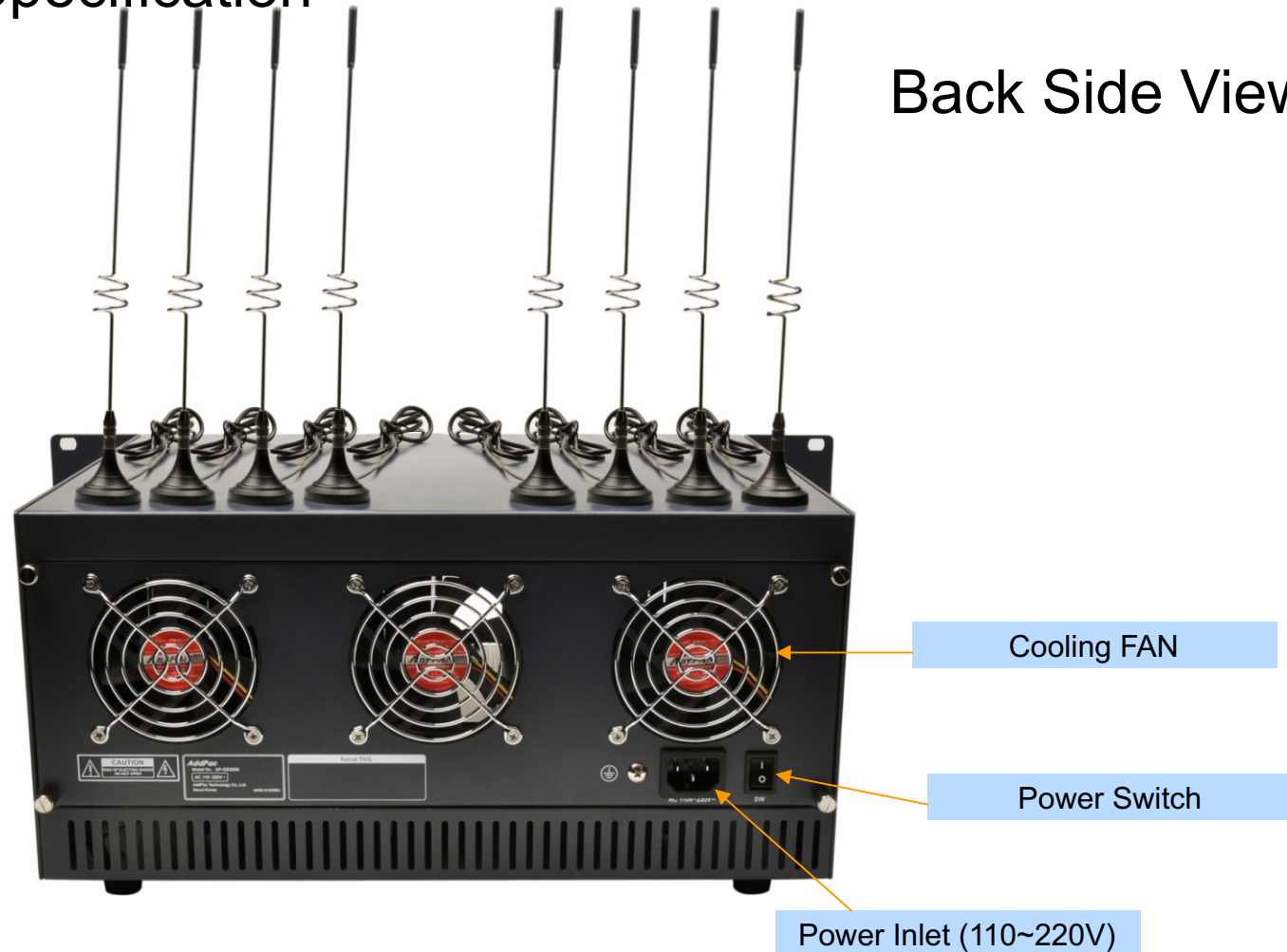

GSM Gateway

AP-GS3000 Multi-Port GSM Gateway

AP-GS3000 Voice Modules

AP-N1-GSM4 4-Port GSM Module



AP-N1-FXS8 8-Port FXS Module



AP-N1-FXO8 8-Port FXO Module



AP-N1-FXS4O4 4-Port FXS&4-Port FXO Module



AP-N1-E1 1-Port Digital E1/T1 Module



Hardware Specification

AP-GS3000 Multi-Port GSM Gateway

RISC
CPU

High-end
DSP

SIM Card Slot



AP-N1-GSM4
(4-Port GSM Module)

GSM Antenna
Internal 4Ch Combiner

Hot-Swap Switch

Port LEDs

Hardware Specification

AP-GS2000 Multi-Port GSM Gateway

RISC
CPU

High-end
DSP

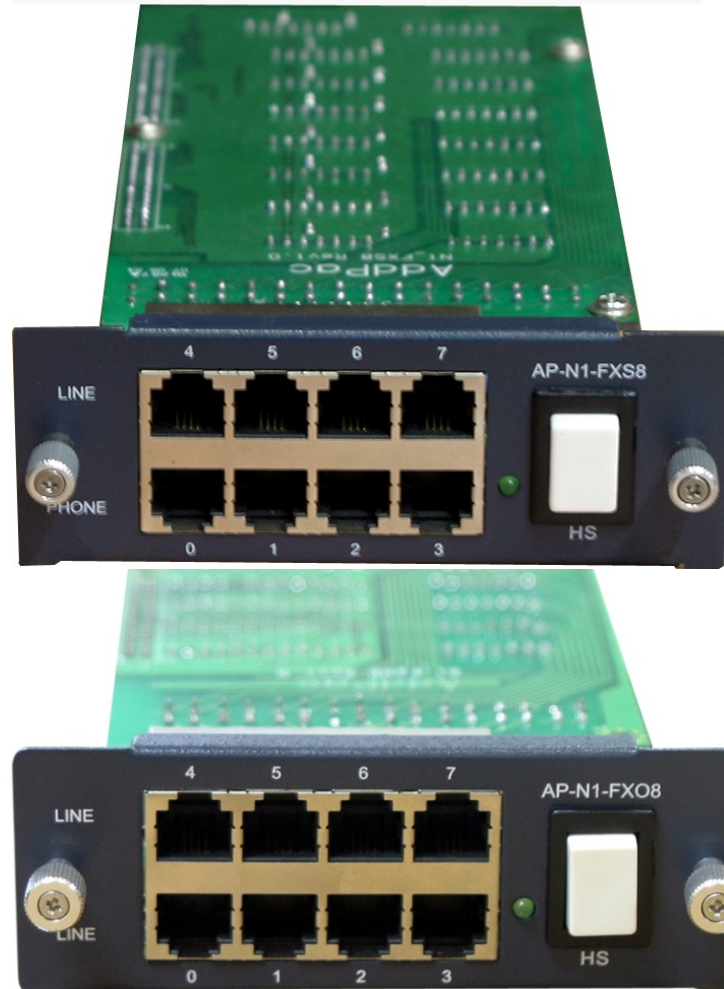

AP-N1-FXS8
(8-Port FXS Module)

AP-N1-FXO8
(8-Port FXO Module)

Hardware Specification

AP-GS3000 Multi-Port GSM Gateway

RISC
CPU

High-end
DSP

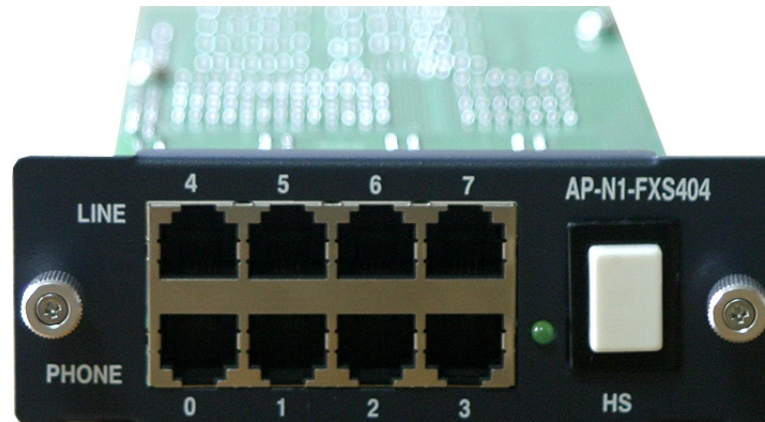

AP-N1-FXS404
(4-Port FXS-
4-Port FXO Module)

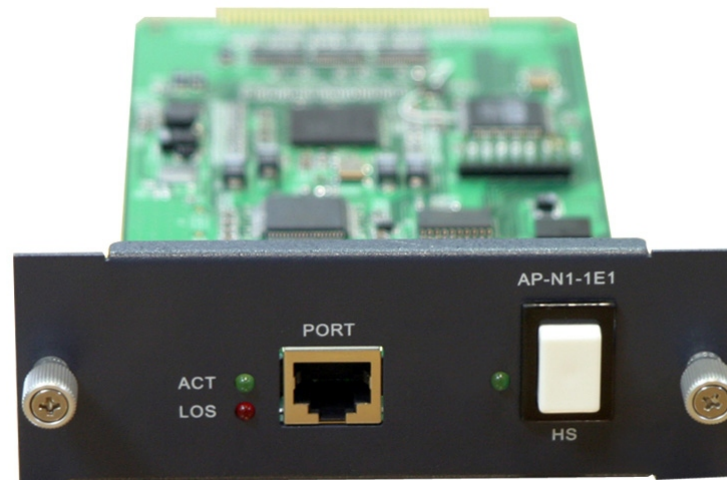

AP-N1-E1
(Digital E1/T1 Module)

Hardware Specification

AP-GS3000 Multi-Port GSM Gateway

RISC
CPU

High-end
DSP

GSM Gateway Service Diagram

AP-N1-GSM4 4-Port GSM Module Internal H/W Block Diagram

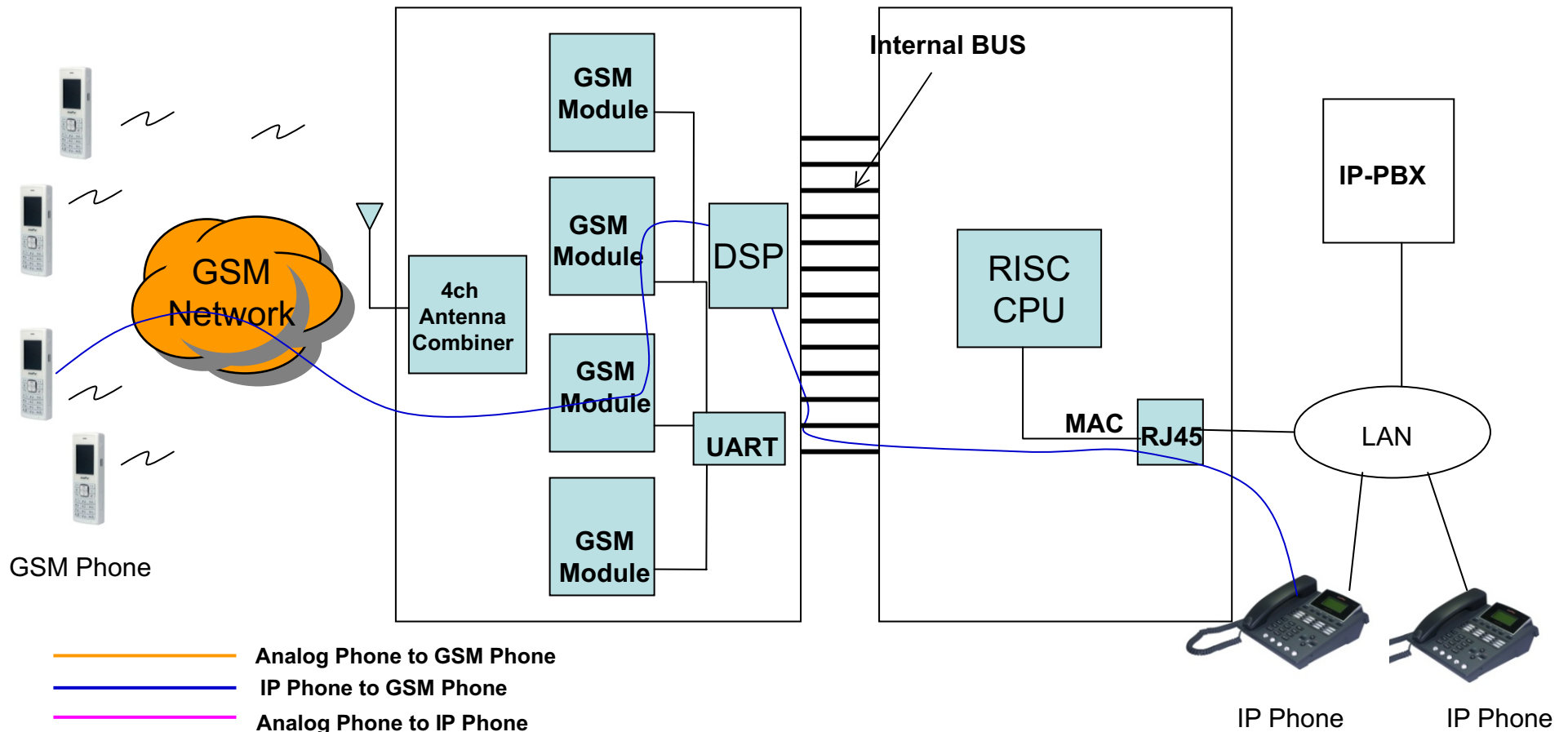

- Analog Phone to GSM Phone
- IP Phone to GSM Phone
- Analog Phone to IP Phone

AddPac

www.addpac.com

Hardware Specification

AP-GS3000 Multi-Port GSM Gateway

RISC
CPU

High-end
DSP

GSM Gateway Service Diagram

32-Port GSM Gateway Service Diagram

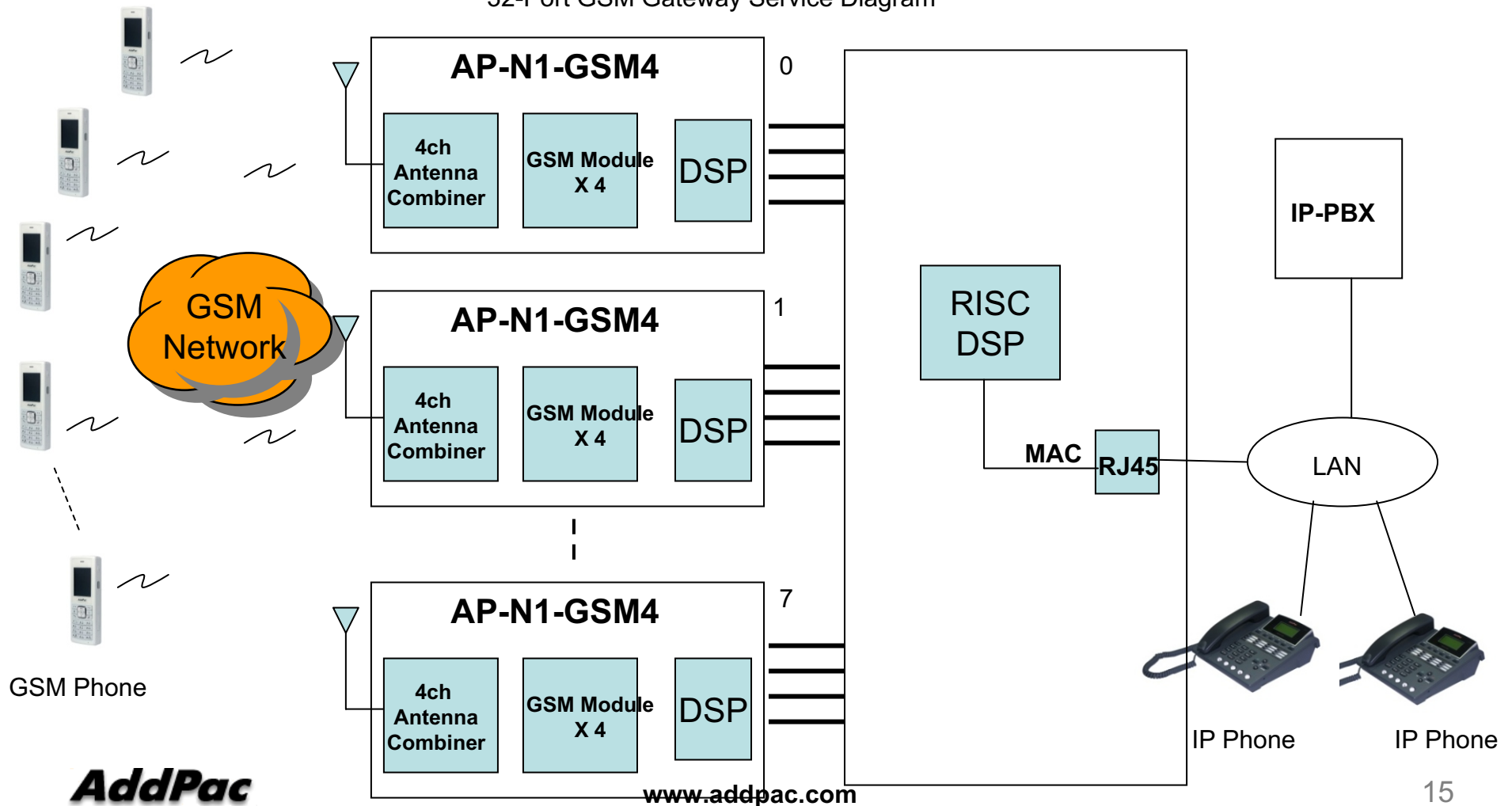

Hardware Specification

AP-GS3000 Multi-Port GSM Gateway

RISC
CPU

High-end
DSP

GSM Gateway Service Diagram

24-Port GSM(4x6Module) + 24-Port(8x3Module) FXS Gateway Service Diagram

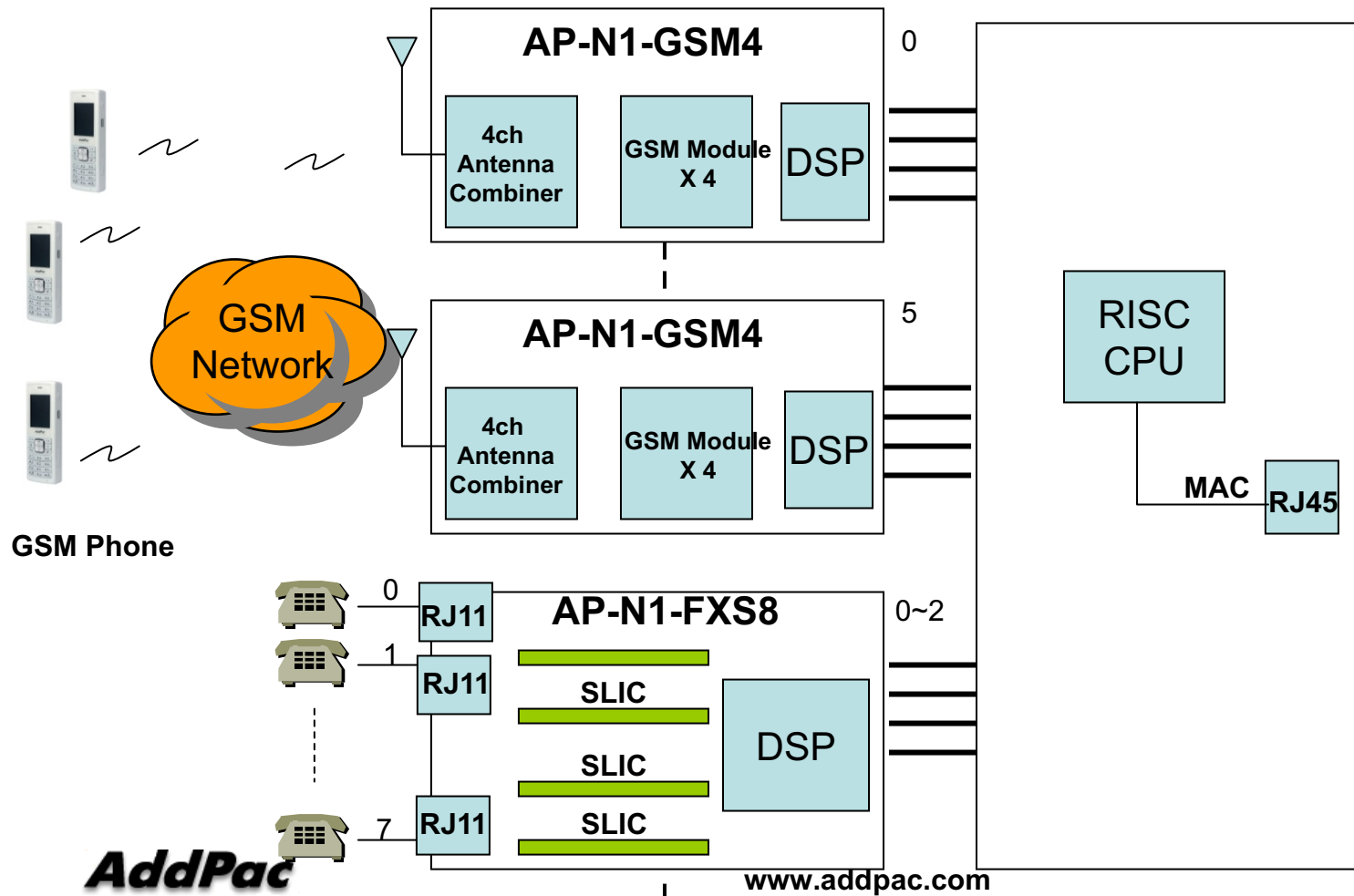

Hardware Specification

AP-GS3000 Multi-Port GSM Gateway

RISC
CPU

High-end
DSP

GSM Gateway Service Diagram

32-Port GSM + 1-Port Digital E1/T1 Service Diagram

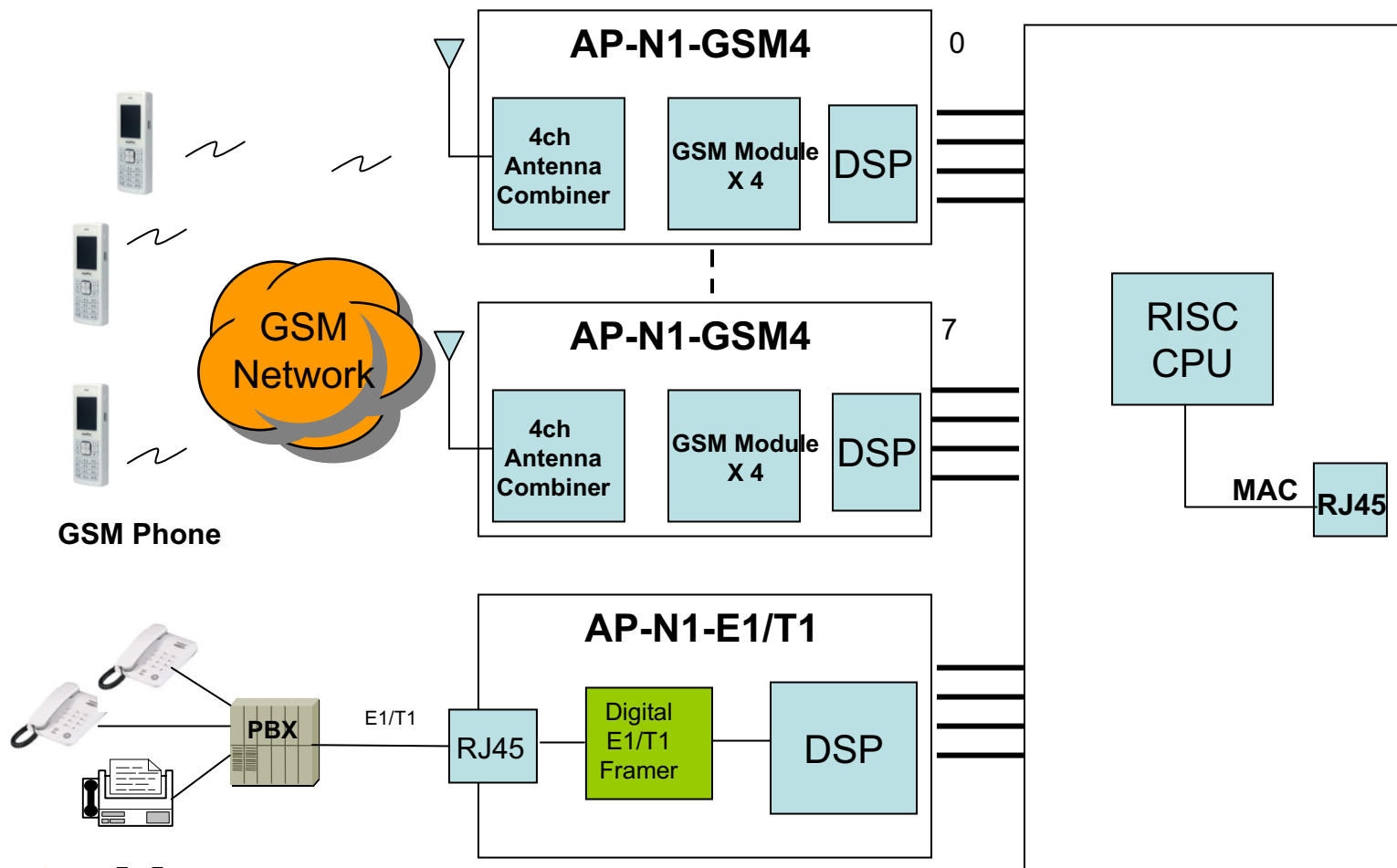

AddPac

www.addpac.com

GSM Module Specification

AP-GS3000 Multi-Port GSM Gateway

- ? Bearers : GSM + GPRS class 10
- ? Quad-Band EGSM 850/900/1800/1900MHz
- ? Normal Sensitivity
 - 850MHz Rx -104 dBm
 - 900MHz Rx -104 dBm
 - 1800MHz Rx -102 dBm
 - 1900MHz Rx -102 dBm
- ? Tx Performances
 - 850MHz Tx +33 dBm
 - 900MHz Tx +33 dBm
 - 1800MHz Tx +30 dBm
 - 1900MHz Tx +30 dBm
- ? Power Consumption
 - 17 uA Sleep Mode, 1.7mA Idle Mode, 400mA GPRS class10 (33 dBm)
- ? Codec
 - FR-EFR-HR-AMR

VoIP (Voice over IP) Service

AP-GS3000 Multi-Port GSM Gateway

? H.323, SIP, and MGCP Triple Stack

? H.323

- ? ITU-T Standard H.323 v3 Support
- ? Support H.245 Tunneling
- ? Including H.235 Security Features

? SIP

- ? IETF RFC3261 or RFC2543 SIP Standard

? MGCP

- ? IETF RFC2705bis-02 Standard MGCP 1.0

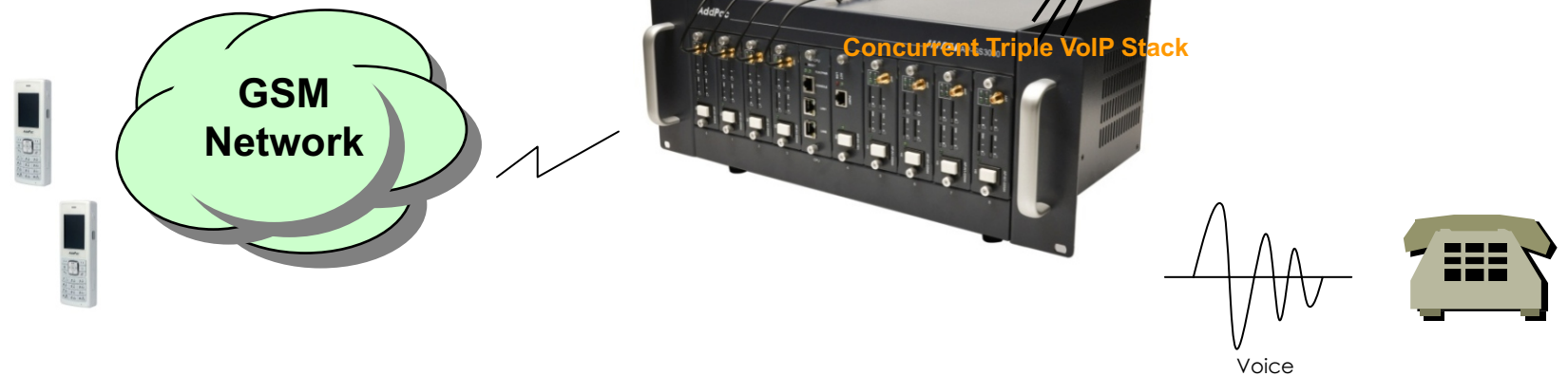

VoIP (Voice over IP) Service

AP-GS3000 Multi-Port GSM Gateway

? H.323

- ? Fast connect, normal connect support
- ? H.245 tunneling support
- ? Q.931 response message setting for inbound VoIP calls
- ? H.245 logical channel open timing selection function
- ? Start H.245 procedure support
- ? DTMF / Hook flash relay with H.245 alphanumeric / signal
- ? Secondary gatekeeper support
- ? Gatekeeper assignment according to the domain name
- ? Gatekeeper discovery with multicast
- ? Lightweight RRQ support
- ? Signaling TCP port assignment
- ? Resource threshold setting with RAI
- ? H.235 clear-token, crypto-token support
- ? canMapAlias support
- ? Technical prefix (supported prefix) support
- ? Public IP assignment in NAT environment

? SIP

- ? Gateway-based / Endpoint-based registration support
- ? Secondary proxy-server assignment function
- ? SIP signaling port change function
- ? SIP proxy server assignment according to the domain name
- ? T.38 real-time fax relay support
- ? DTMF relay support with RFC2833 / OPTION message
- ? Re-INVITE support

? MGCP

- ? Secondary call agent assignment function
- ? Default package assignment
- ? Announcement Server Package, Generic Media Package, Handset Package, Line Package, Trunk Package support
- ? MGCP call agent assignment according to the domain name
- ? T.38 real-time fax relay support
- ? DTMF relay support based on RFC2833

VoIP (Voice over IP) Service

AP-GS3000 Multi-Port GSM Gateway

? Voice Codec

- ? G.711 A-Law, G.711 U-Law
- ? G.726 r16, G.726 r32
- ? G.729A
- ? G.723.1 r63, G.723.1 r53
- ? VAD (Voice Activity Detection) function support
- ? DTMF relay support (H.323, SIP, MGCP common) based on RFC2833

? RTP

- ? Redundant RTP packet transmission in case of severe packet loss
- ? Dynamic jitter buffer management and RTP packet jitter and loss compensation with heuristic & DSP error concealment
- ? Static jitter buffer setting support
- ? Voice frame per RTP packet number control for each codec
- ? In-band ring-back tone support
- ? Virtual ring-back tone support
- ? Tone parameter change support

? FAX

- ? Fax relay mode supporting T.38, inband-T.38, bypass mode
- ? Lost packet compensation with redundant setting in case of T.38 fax relay
- ? Fax relay mode, rate setting for remote end

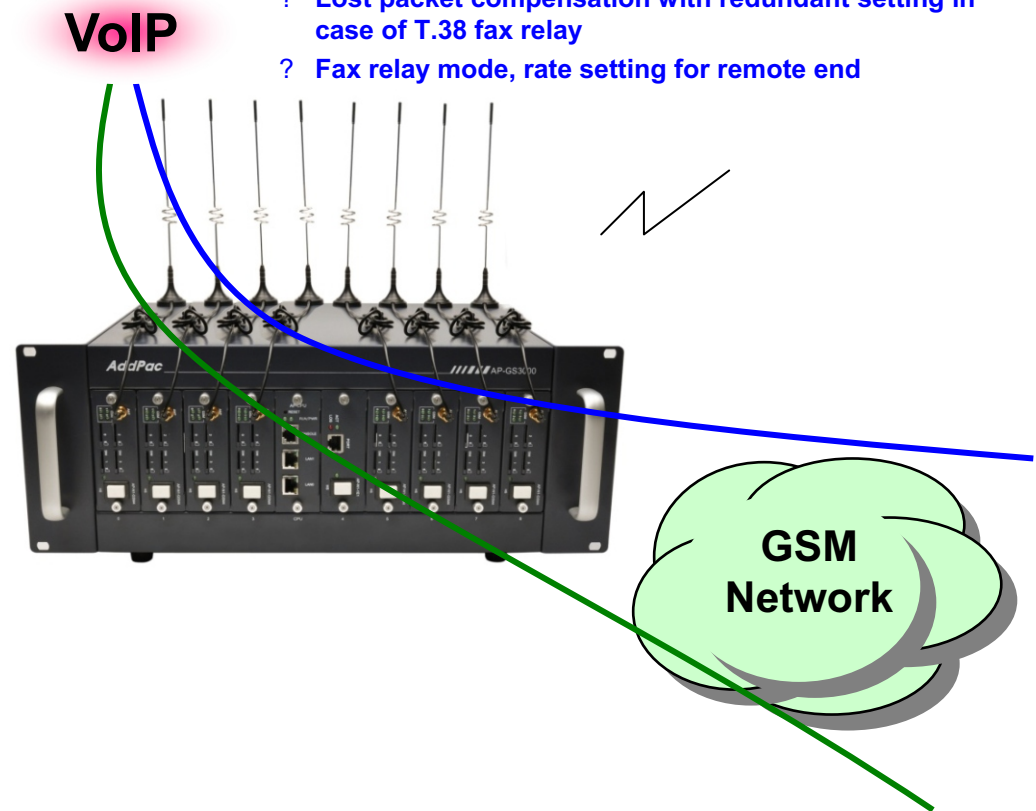

VoIP (Voice over IP) Service

AP-GS3000 Multi-Port GSM Gateway

? VoIP Call Controls

- ? Hot line connection function with PLAR (Private Line Auto Ring Down)
- ? Leased line emulation function
- ? Connection monitoring function
- ? Fault tolerant with Redundancy and Call Distribution among Gateways for load balancing
- ? Call attempt with IP address
- ? H.323, SIP, MGCP inbound call connection for each voice port
- ? Multiple E.164 setting for one voice port
- ? One E.164 or digit pattern can be assigned to more than one voice port
- ? Hunting with Longest match/ priority/ sequence/ random
- ? One stage call setup by Digit forwarding
- ? Call barring with specific digit patterns
- ? Calling and called number conversion for PSTN outbound calls
- ? PSTN rerouting in case of VoIP call attempt failure

? VoIP Call Controls (cont.)

- ? Call transfer for internal calls
- ? Call pickup for internal calls
- ? Calling and called number conversion for VoIP outbound calls
- ? Calling and called number conversion for VoIP inbound calls
- ? Fax broadcasting call control

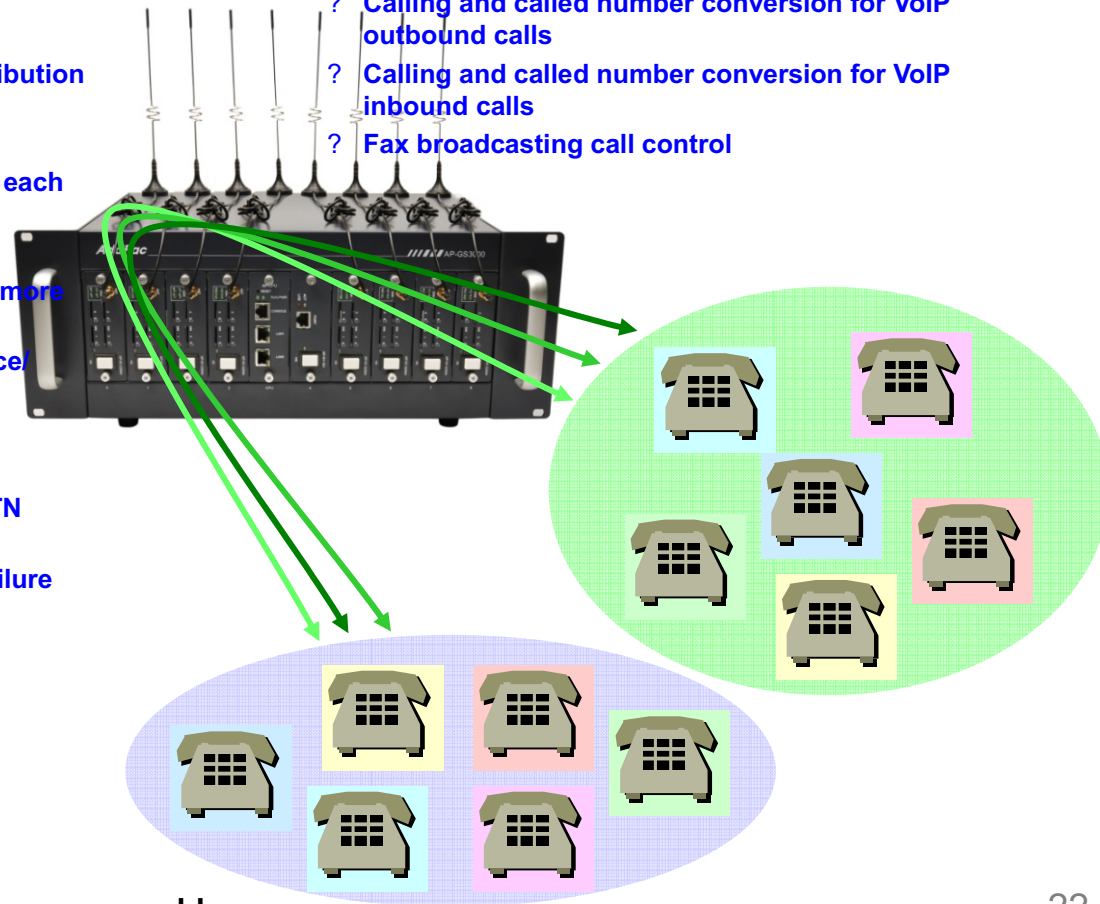

Advanced QoS Features

AP-GS3000 Multi-Port GSM Gateway

? Enhances **Transmit** Voice QoS Features

- ? Voice Traffic Priority Queuing
- ? QoS Service Profiling
- ? Providing Virtual Network Transmit Algorithm
- ? Real-time Voice Traffic QoS Support
- ? RTP Packet Transmit Interval Control
- ? Supporting RTP Packet Redundancy Scheme
- ? IP Header Control such as ToS, Diffserv

? Enhances **Receive** Voice QoS Features

- ? Dynamic Jitter Buffer Management
- ? Error Concealment
- ? Support T.38 FAX Data Error Recovery Scheme

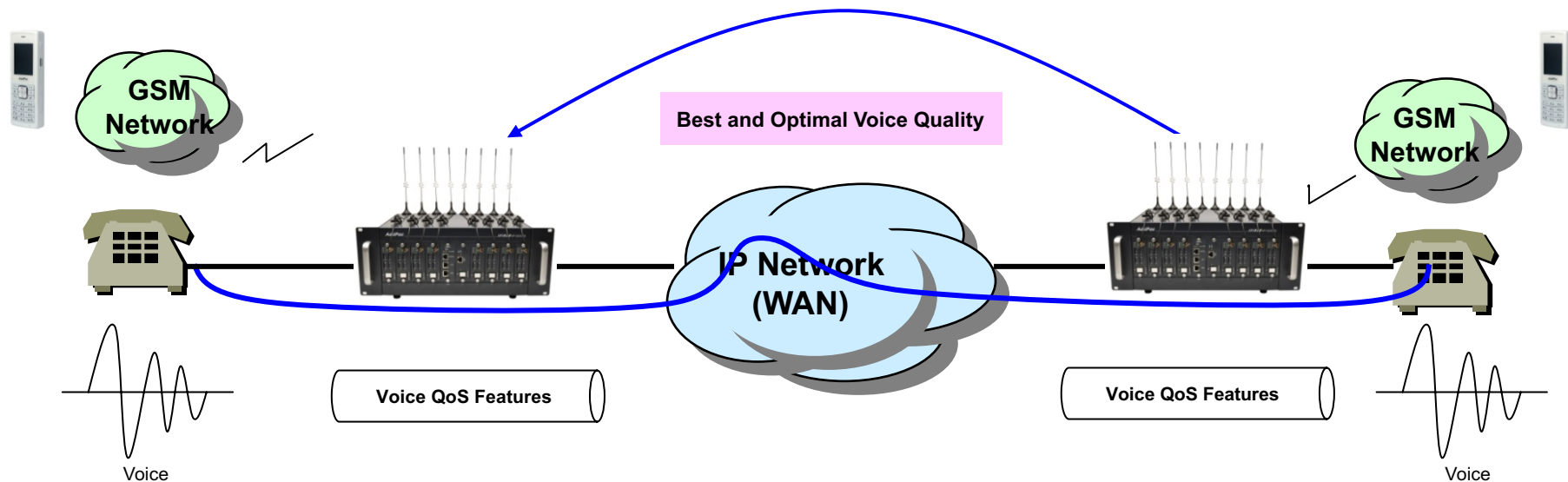

Network Protocols

AP-GS3000 Multi-Port GSM Gateway

Basic Network Protocols

- ARP, IPv4, TCP, UDP, ICMP, SCTP, IGMP, MLD

Routing Protocol

- IPv4 : Static

Service Protocol

- FTP, Telnet, TFTP, DHCP Server/Relay, SNMP Server
- CDP (Cisco Discovery Protocol)
- DNS Resolver , DDNS(nsupdate)
- Bridge
- Syslog

IPv4 Address Configuration

- Fixed (Static)
- DHCP
- PPPoE

Miscellaneous

- Cisco Style CLI
- Standard & Extended IPv4 Access List
- Multi-level User Account Management
- IP accounting
- STUN Client

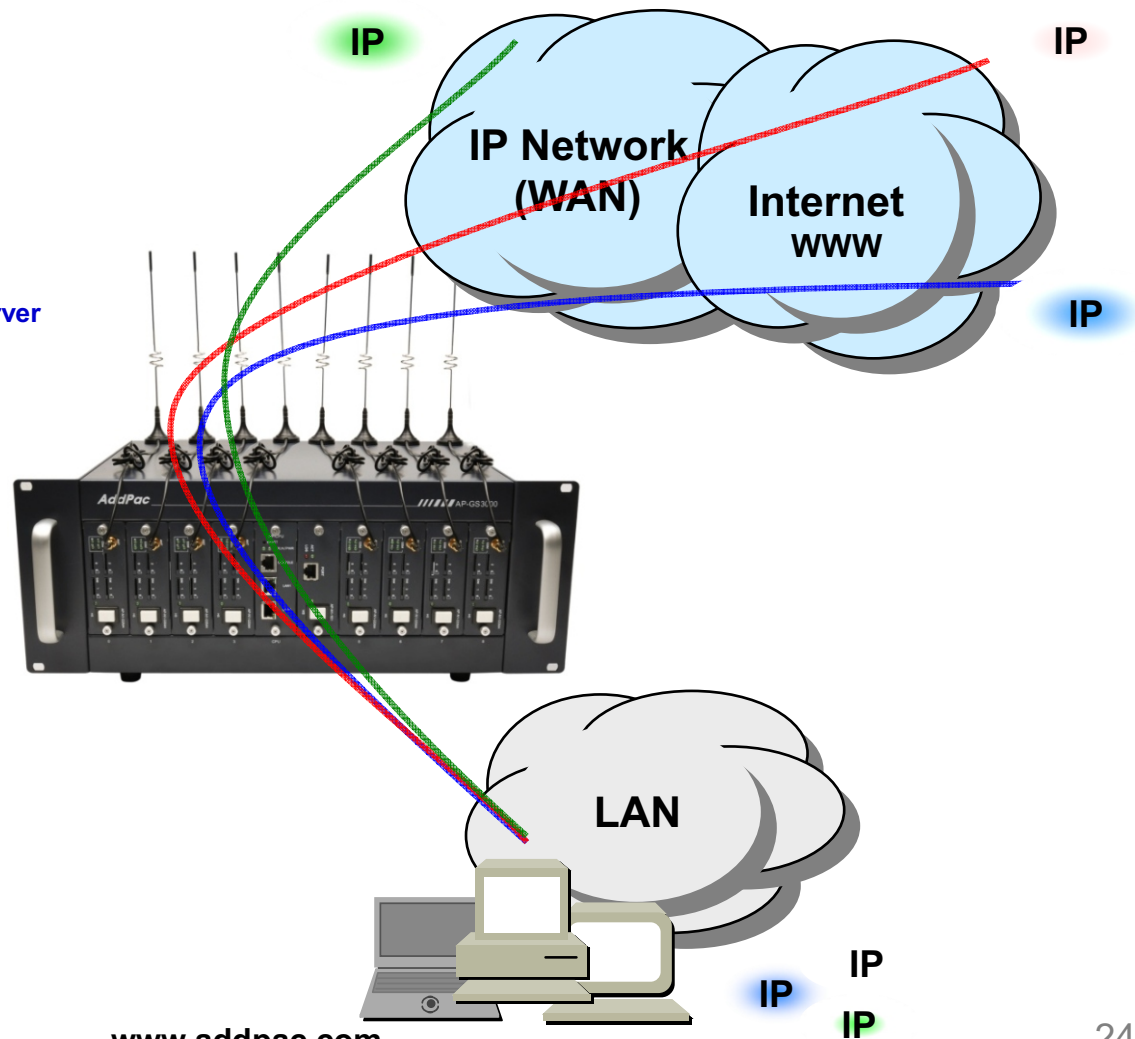

Network Management

AP-GS3000 Multi-Port GSM Gateway

? SNMP

- ? Standard Simple Network Management Protocol(SNMP) Agent support
- ? MIB v1 and v2 Support

? Web-based Management

- ? Smart Easy Setup
- ? Standard Voice Interface
- ? Standard PSTN Back-up Interface

? Watch-dog Function

- ? Hardware, Software watch-dog services

? Remote Management

- ? Telnet
- ? Rlogin

? Auto Upgrade Service

- ? HTTP server based APOS image and configuration file auto-upgrade support

? Batch Job Function

- ? Text based script downloading

? Interoperable with AP-VPMS Service

- ? AddPac VoIP Plug & Play Management System (AP-VPMS)

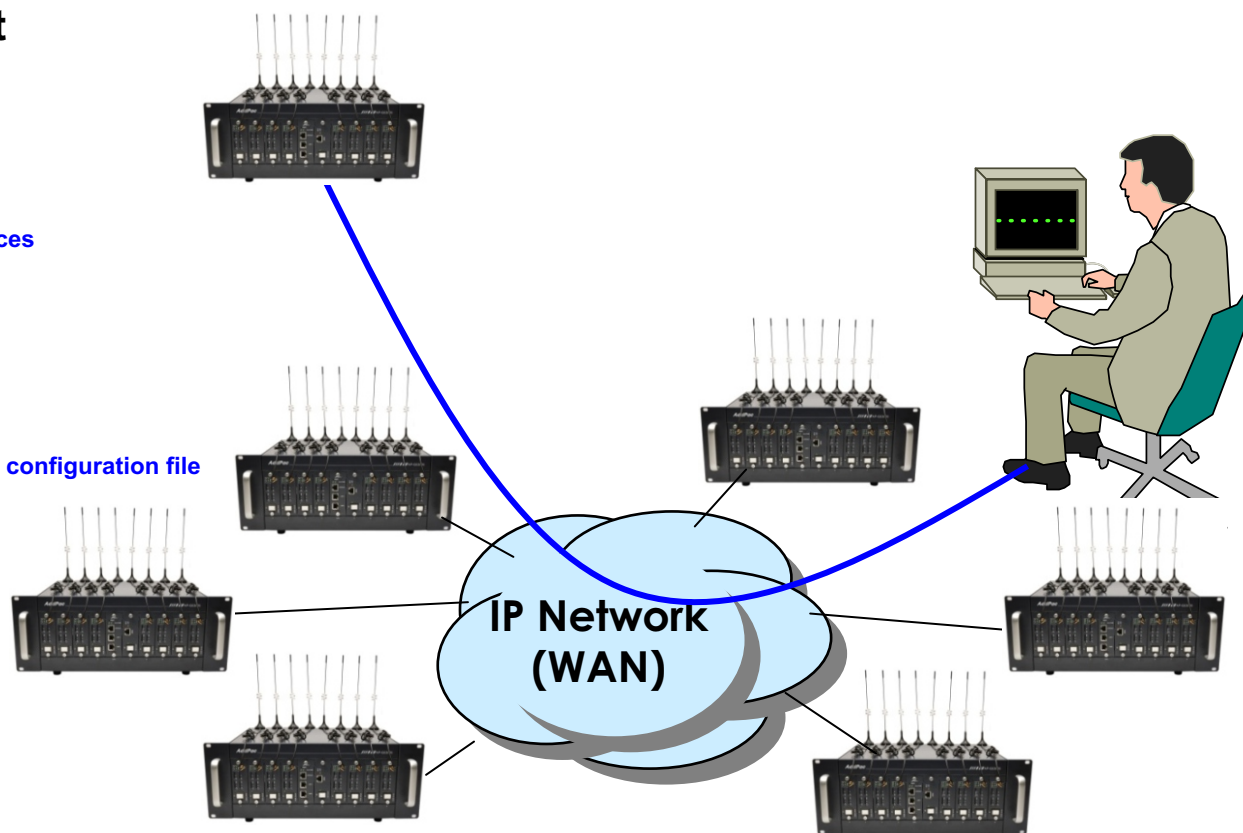

Smart Web Manager

AP-GS3000 Multi-Port GSM Gateway

? System Configuration

? Network Setup, Language, NAT, PPTP, NTP

? Basic Configuration

? Protocol, SIP Server , FXS Extension, GSM Extension

? DTMF/CODEC, VoIP Dial Plan, GSM Dial Plan, Static Routing, Hot Line

? Advanced Configuration

? Gain/CID, GSM PINs, FAX, Service, Filtering, Security

? GSM Web Callback, GSM Callback

? Miscellaneous Configuration

? Call Status, System Status, Alarm Status, GSM Status

? Call Log, System Log, Ping, BTS Selection, GSM BTS Info

? LCR(Least Cost Routing)

? Black & White List, Time Interval, Tariff Group, LCR Test

短信MS

? Inbox, SMS New Message

Smart Web Manager : Main Page Layout

AP-GS3000 Multi-Port GSM Gateway

Main Menu
For easy system setup, provide the various menu and category

- System
 - Network Setup
 - Language
 - NAT
 - PPTP
 - NTP
- Basic
 - Protocol
 - Server SIP
 - SIP Registration
 - FXS Extension
 - GSM Extension
 - DTMF/CODEC
 - VoIP Dial Plan
 - GSM Dial Plan
 - Static Route
 - Hot Line
- Advanced
 - Gain & CID
 - GSM PINs
 - Fax
 - Service
 - Filtering
 - Security
 - SNMP
 - WEB Callback
 - GSM Callback

Tool Bar
Provide frequently used tools like as System Update, Configuration Backup, Initialization, Restart, Telnet

System Information

H/W Version	2.0
S/W Version	8.00d
MAC Address	0002.a400.0000
VoIP Protocol	SIP
Voice Interface Module	G(2)S(2)
Registration Status	Registered
Supported Codec List	
Network Information	Static 172.16.9.16
WAN LINK Status	100Mbps FULL Duplex Link UP
LAN LINK Status	Link Down
Current Time	Fri Jan 1 01:49:57 2010
System Startup Time	Fri Jan 1 00:00:00 2010
	0 days 01:49:57
	0

Information
Display the current system version and status summary

AddPac Technology
Model : GS1002_G2
H/W Version : 2.0
S/W Version : 8.00d
Smart Web Version : 0.4
Smart Web Build : Mar 24 2010
Voice Interface
G(2)S(2)
Protocol : SIP
Status : Registered
CurrentCalls: 0 Call
Network : Static 172.16.9.16
Mac Address: 0002.a400.0000
Unread Message:
P0:0(0)
P0:1(0)

Description
Display the help message if you move mouse over main menu

Workspace
Workspace for detailed action

Smart Web Manager : System ? Network Setup

AP-GS3000 Multi-Port GSM Gateway

The screenshot shows the 'Network Setup' page in the Smart Web Manager interface. The page is divided into several sections, each with a radio button for selection:

- Static IP:** Includes fields for IP Address (172.16.9.16), Network Mask (255.255.0.0), Default Router (172.16.1.1), and DNS Server (Primary and Secondary).
- PPPoE(ADSL):** Includes fields for Username and Password.
- DHCP:** A simple selection option.
- VLAN:** Includes a field for ID (0).
- WAN Link Control:** Includes options for Auto/Manual, Speed (100/10), and Duplex (full/half).
- MAC(Hardware) Address:** A field for the MAC address.

On the right side, there is an 'Information' panel with details like Model (GS1002_G2), Smart Web Version (0.4), and Network status (Static 172.16.9.16). Below it is a 'Description' panel with a note about WAN port setup.

Yellow callout boxes on the left provide detailed explanations for each configuration option:

- Host Name:** Create a representative name for the site to be installed.
- Static IP:** This is static IP mode. Specify the addressed IP from the service provider.
- PPPoE:** This is ADSL mode. This mode is used for addressing IP though authentication from the modem. At this time, the modem must be configured in a way that the device can be authenticated.
- DHCP:** This is dynamic IP mode which is set at default. The IP can be addressed from the external DHCP server.
- VLAN:** Configure VLAN mode and ID.
- WAN Link:** Controls and recognizes WAN port. Specify the connection speed of WAN port. connection automatically.
- MAC:** Change MAC address of WAN interface. Without address entry, use the basic MAC Address.

An additional callout points to the 'Unread Message' section in the Information panel, which lists 'Unread Message: P0:0(0) P0:1(0)'.

Smart Web Manager
www.addpac.com

System

- Network Setup
- Language
- NAT
- PPTP

System

- Server SIP
- SIP Registration
- FXS Extension
- GSM Extension**

Advanced

- Gain & CID
- GSM PINs
- Fax
- Service
- Filtering
- Security
- SNMP
- WEB Callback
- GSM Callback

Miscellaneous

- Call Status
- System Status
- Alarm Status
- GSM Status
- Call Log
- System Log
- Ping
- BTS Selection
- GSM BTS Info

GSM Extension

Port Information

Port	P0	P1	P2	P3
SLOT0	GSM	GSM	FXS	FXS

GSM Extension Configuration

Index	Port	Numbers	Preference	HuntStop	Select
0	0/0	T	0	X	<input type="checkbox"/>

GSM Extension with Translation

Port	Destination Pattern	Digits to Insert	Number of Digits to Delete
P0:0	33	8	1
P0:1			0

Information

AddPac Technology
Model : GS1002_G2
H/W Version : 2.0
S/W Version : 8.00d
Smart Web Version : 0.4
Smart Web Build : Mar 24 2010
Voice Interface
G(2)S(2)
Protocol : SIP
Status : Unregistered
CurrentCalls: 0 Call
Network : Static 172.16.9.16
Mac Address: 0002.a400.0000
Unread Message:
P0:0(0)
P0:1(0)

Description

Set up for using GSM port to extension number (forwarding No)

Port Information
voice port type & physical port

GSM Extension
Configure GSM phone-number for

GSM Extension with Translation
Used to GSM callback

- The Received CID is not real serving number.
- The specified translation rule is applied.