



AP6500™ (128 Port) Analog VoIP Gateway

High Performance VoIP Gateway Solution

Frequent Ask Question



AddPac

AddPac Technology

Sales and Marketing

www.addpac.com

Frequent Ask Question

1. Detailed Explanation about Back Panel Interface of AP6500 System
2. System Redundancy Operation
 - CPU Fault, LAN Interface Fault
 - FXS, FXO Line Interface Card Fault
3. What is mean of Steady and Reliable Fault Tolerant Service ?

AP6500 VoIP Gateway provides the seamless VoIP service. For example, already connected VoIP calls would not be disconnected because of standby CPU knows the connected VoIP call information via keep alive channel with Active CPU board. But, compressed Voice Packets (G.729, etc) of each VoIP call will be lost very shortly or not.

And, AP6500 can process the new arrival calls during failure turnover procedure but some new calls can be lost within very short period or not.

Frequent Ask Question

AP6500 Analog VoIP Gateway

Back Panel Interface Diagram

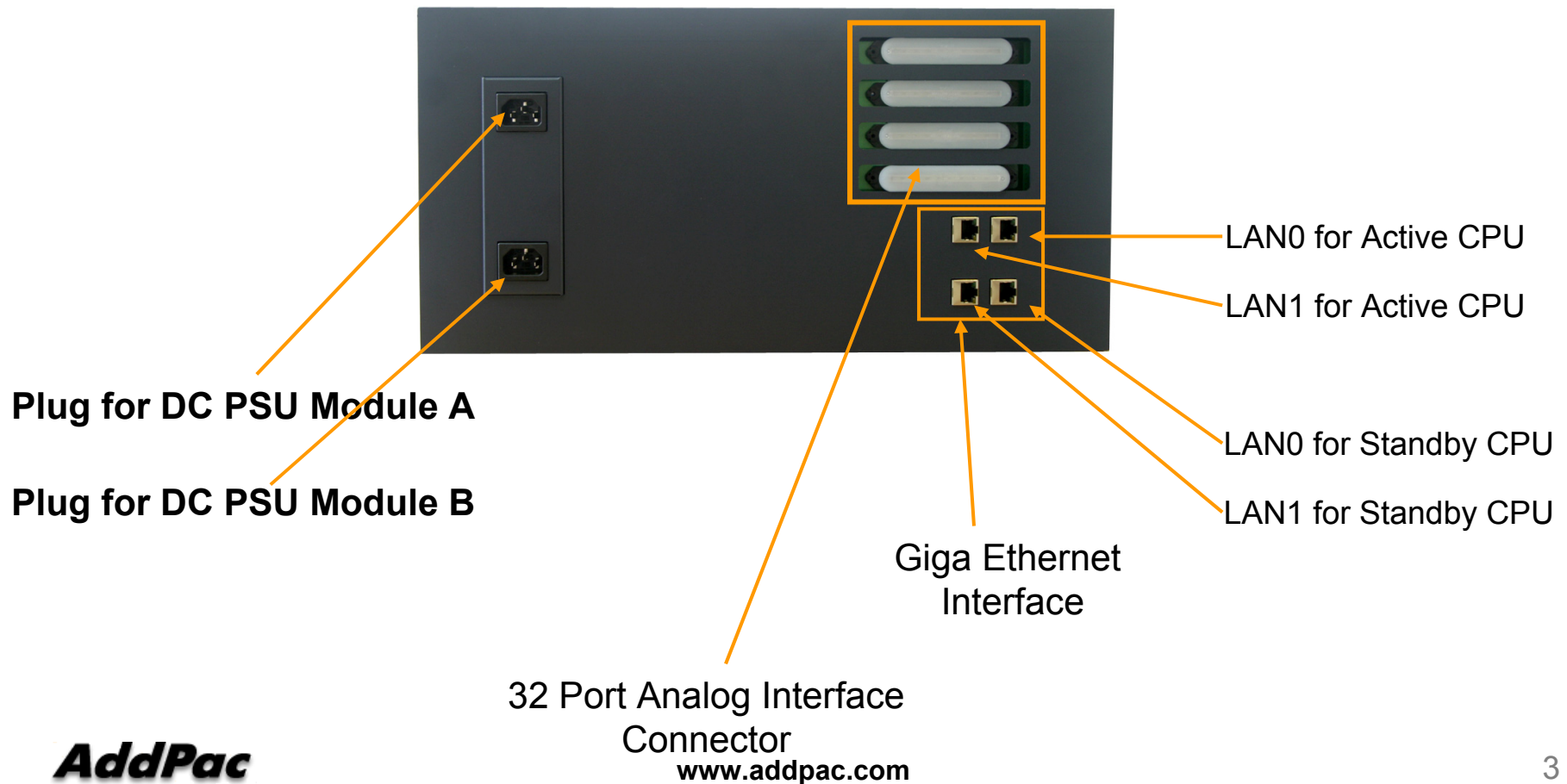

Frequent Ask Question

AP6500 Large Scale VoIP Gateway

AP6500 System Block Diagram

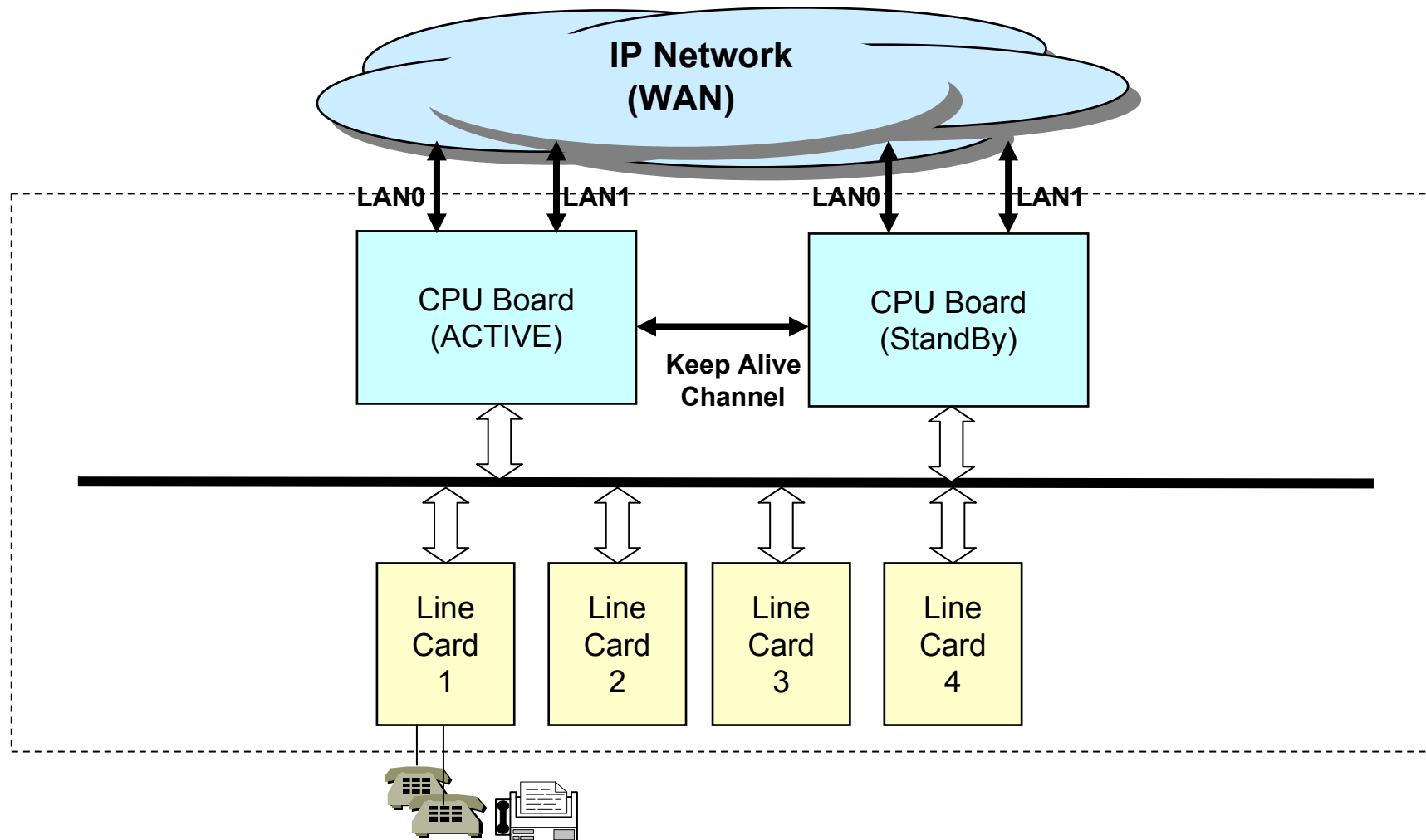

Frequent Ask Question

AP6500 Large Scale VoIP Gateway

1. CPU Fault

- CPU Board Eject/Insert by Admin. User
- Device Fault such as SDRAM Defect.
- LAN Interface Fault.

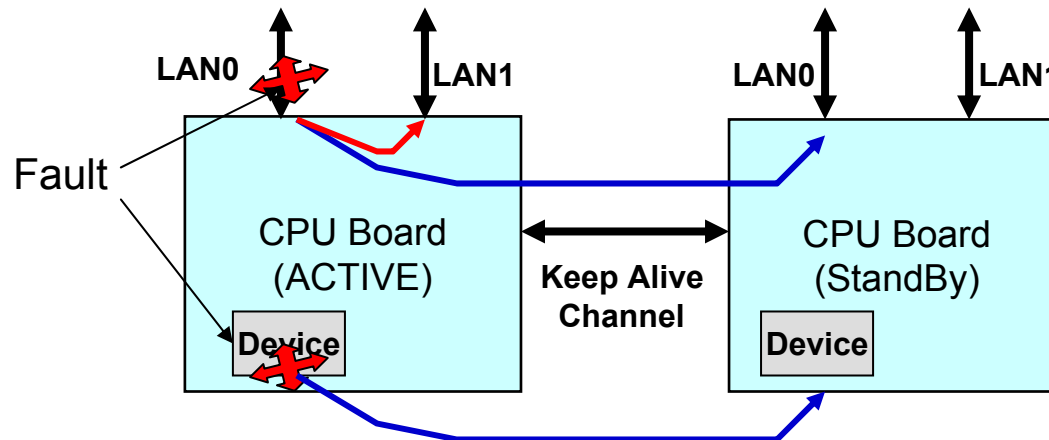

If device fault or link down is occurred in Active CPU board or LAN0 port of Active CPU, Active/Standby CPU board failure turnover procedure will be started as shown above diagram. If necessary, LAN0 to LAN1 failure turnover within Active CPU board may be implemented. Currently, this scheme is not considered yet.

Frequent Ask Question

AP6500 Large Scale VoIP Gateway

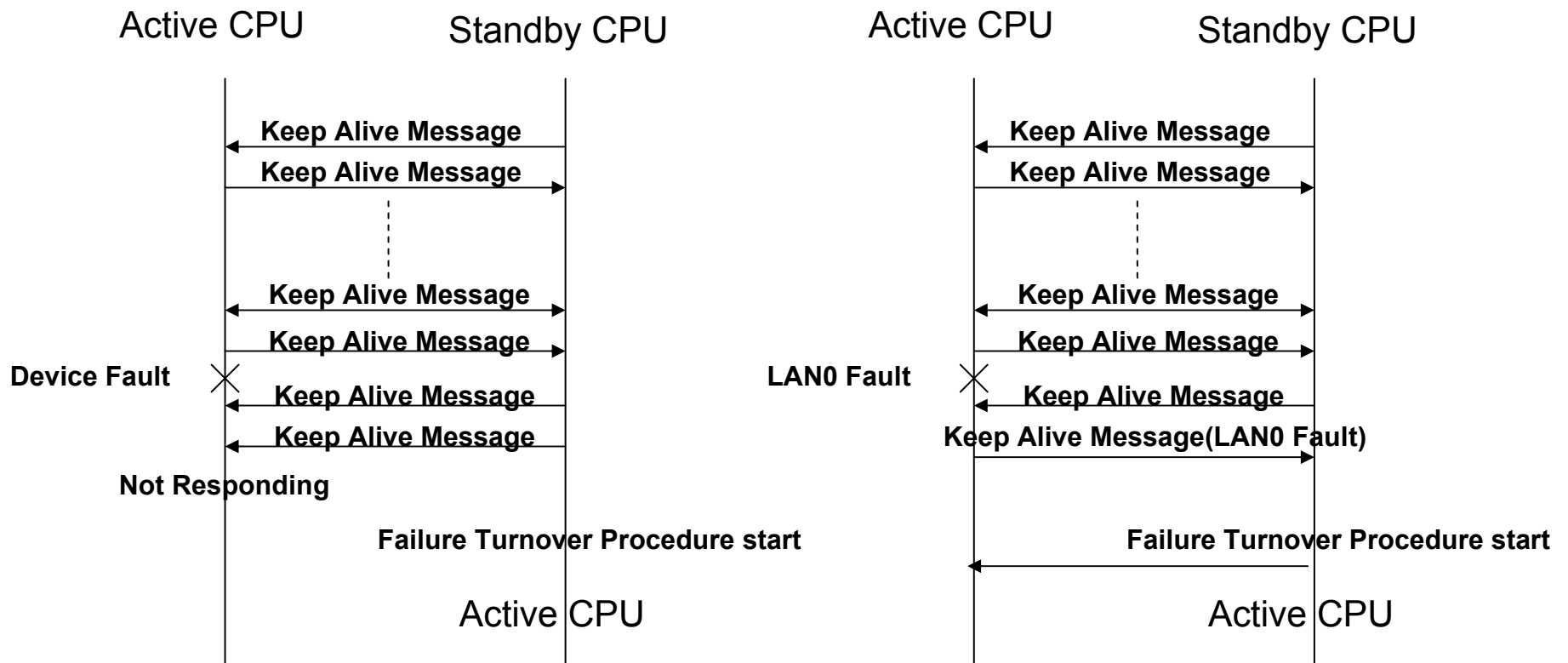

Frequent Ask Question

AP6500 Large Scale VoIP Gateway

Line Interface Card Fault

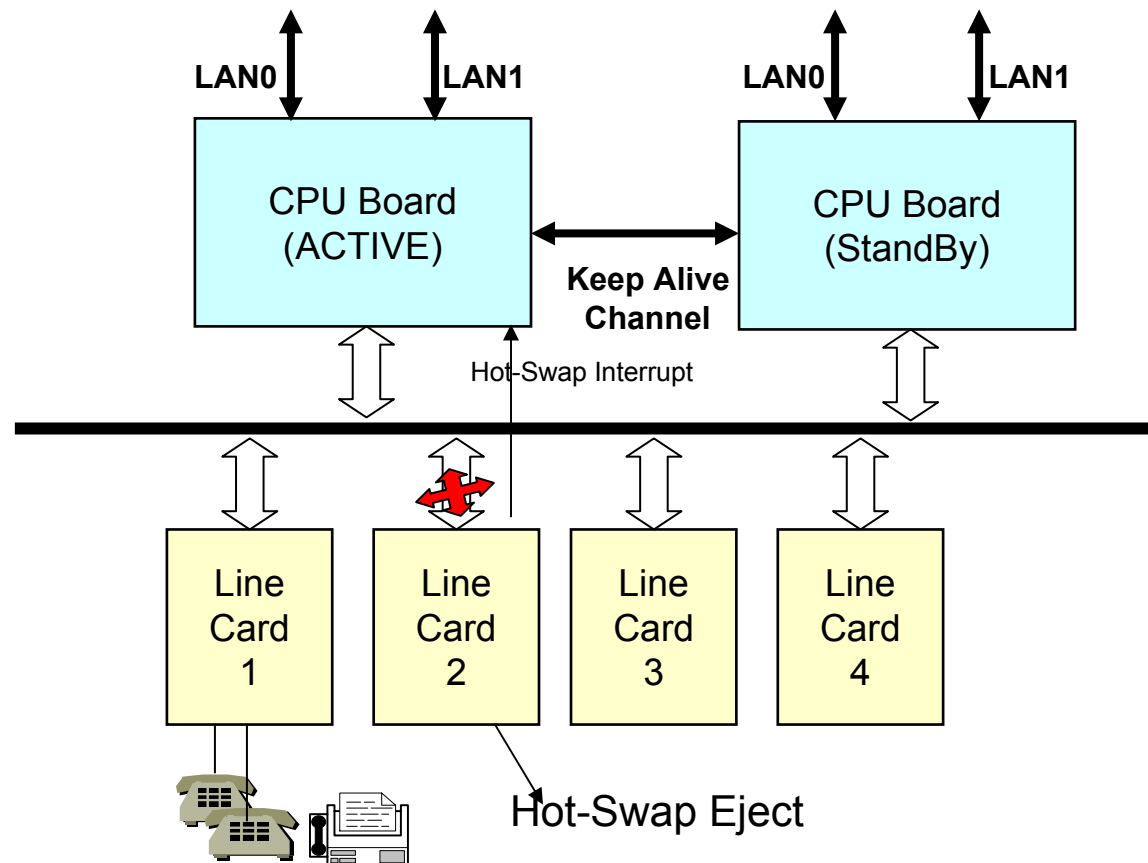



Thank you!

AddPac Technology Co., Ltd.
Sales and Marketing

Phone +82.2.568.3848 (KOREA)

FAX +82.2.568.3847 (KOREA)

E-mail sales@addpac.com