

Reverse Call for Visitor Monitoring Service



AddPac

AddPac Technology

2015, Sales and Marketing

Contents

- Network Diagram
 - Integrated Door Access Control and Call Control
 - Reverse Call Door Open
- Direct Call Configuration
 - Smart Web – Reverse Call Door Open
- DACS System Message Flow
 - Call Flow between Attendant and IP Video Door Phone

Network Diagram

Integrated Door Access Control and Call Control

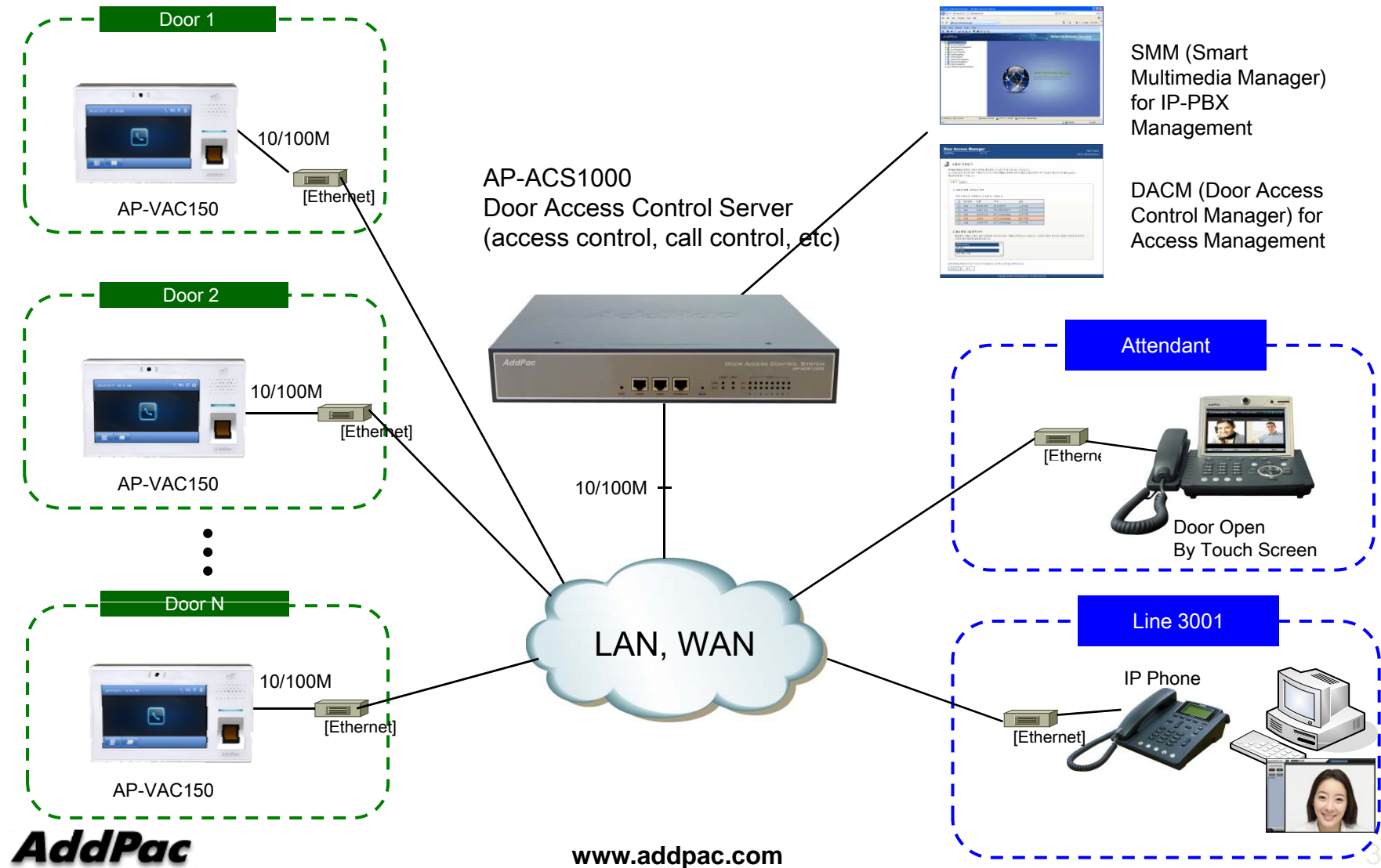

Network Diagram

Reverse Call Door Open

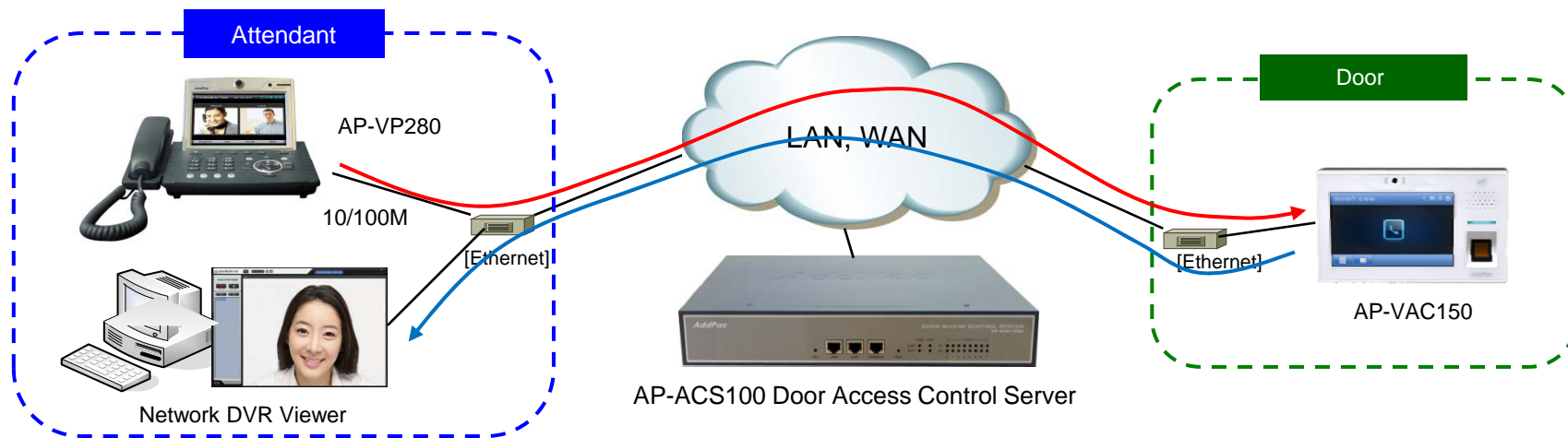

- Door Open Control function when an attendant makes a call to an external IP Video Door Phone
 - Reverse Call Door Open Control
 - Reverse Call Door Open Enable/Disable
 - Direct Auto Answer

Indoor Open Control

Smart Web – Reverse Call Door Open

The screenshot displays the Smart Web Manager interface for configuring Indoor Open Control. The left sidebar shows a navigation menu with categories: System, Call & Media, Door Access Control, and Miscellaneous. The 'Indoor Open Control' option is selected under Door Access Control. The main content area is titled 'Indoor Open Control' and contains several configuration sections:

- Feature Code:** A text input field containing '1' with a note 'using 0-9, #, *'.
- Door Close Time:** A text input field containing '2' with a note 'default 2 sec, 1-180 sec'.
- Authentication:** A section with three checkboxes: Password, RF-Card, and User-Call.
- Dual-Authentication:** A section with one checkbox: RF-Card + Password.
- Received Call Door Open:** A section with two radio buttons: Enable (selected) and Disable. This section is highlighted with a red dashed box.
- Direct Door Open:** A section with an 'Execute' button.

On the right side, there are two panels: 'Information' and 'Description'. The 'Information' panel shows system details like 'AddPac Technology', 'Model: VAC50_G2', and registration status. The 'Description' panel states 'Open/Close the door remotely.'

A yellow callout box at the bottom right of the screenshot contains the following text:

Reverse Call Door Open
Settings for Indoor Open, in receiving a call
Enable / Disable
Direct Auto Answer is applied by checking Enable Button.

DACS System Message Flow

Call Flow between Attendant and IP Video Door Phone

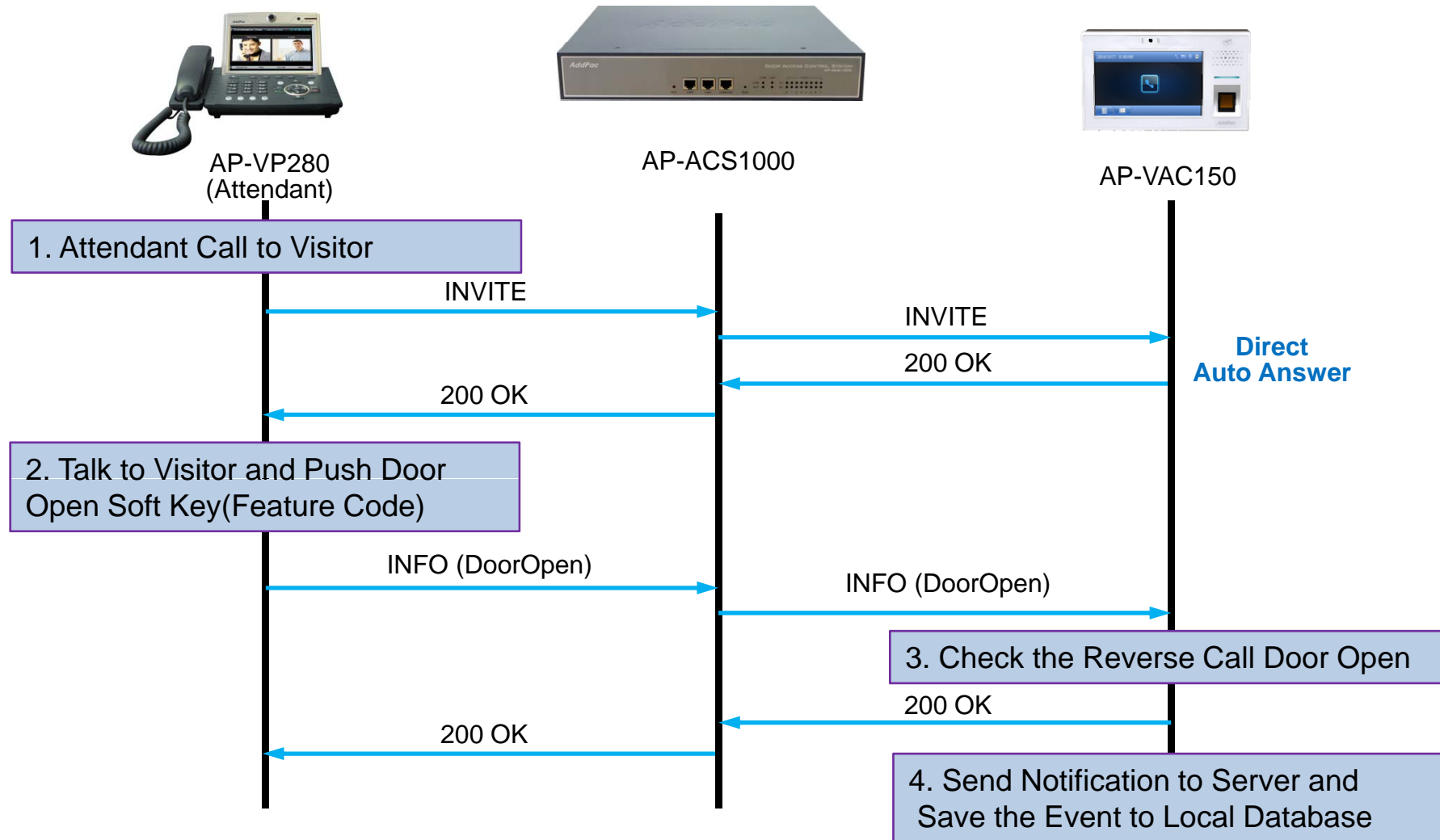



Thank you!

AddPac Technology Co., Ltd.
Sales and Marketing

Phone +82.2.568.3848 (KOREA)

FAX +82.2.568.3847 (KOREA)

E-mail sales@addpac.com