



IPNext180™

IP KeyPhone System

High Performance Hybrid IP-PBX Solution

RTP Proxy Service for Private IP Problem Solving



AddPac

AddPac Technology

2008, Sales and Marketing

www.addpac.com

Contents

- Overview
- RTP Proxy Configuration
 - Public/Private RTP proxy
 - Asymmetric/Symmetric NAT
 - RTP Broadcast
 - RTP Conference
 - IPv4/IPv6 RTP Proxy
- Signal Flow Diagram

Service Overview

- Protocol Independence (H.323, SIP, MGCP)
- Support RTP Proxy without NAT
- Support Symmetric / Asymmetric NAT
- Support IPv4/IPv6 RTP Proxy
- Support RTP Broadcast
- Support RTP Conference

RTP Proxy Configuration



Public/Private RTP Proxy without NAT Router

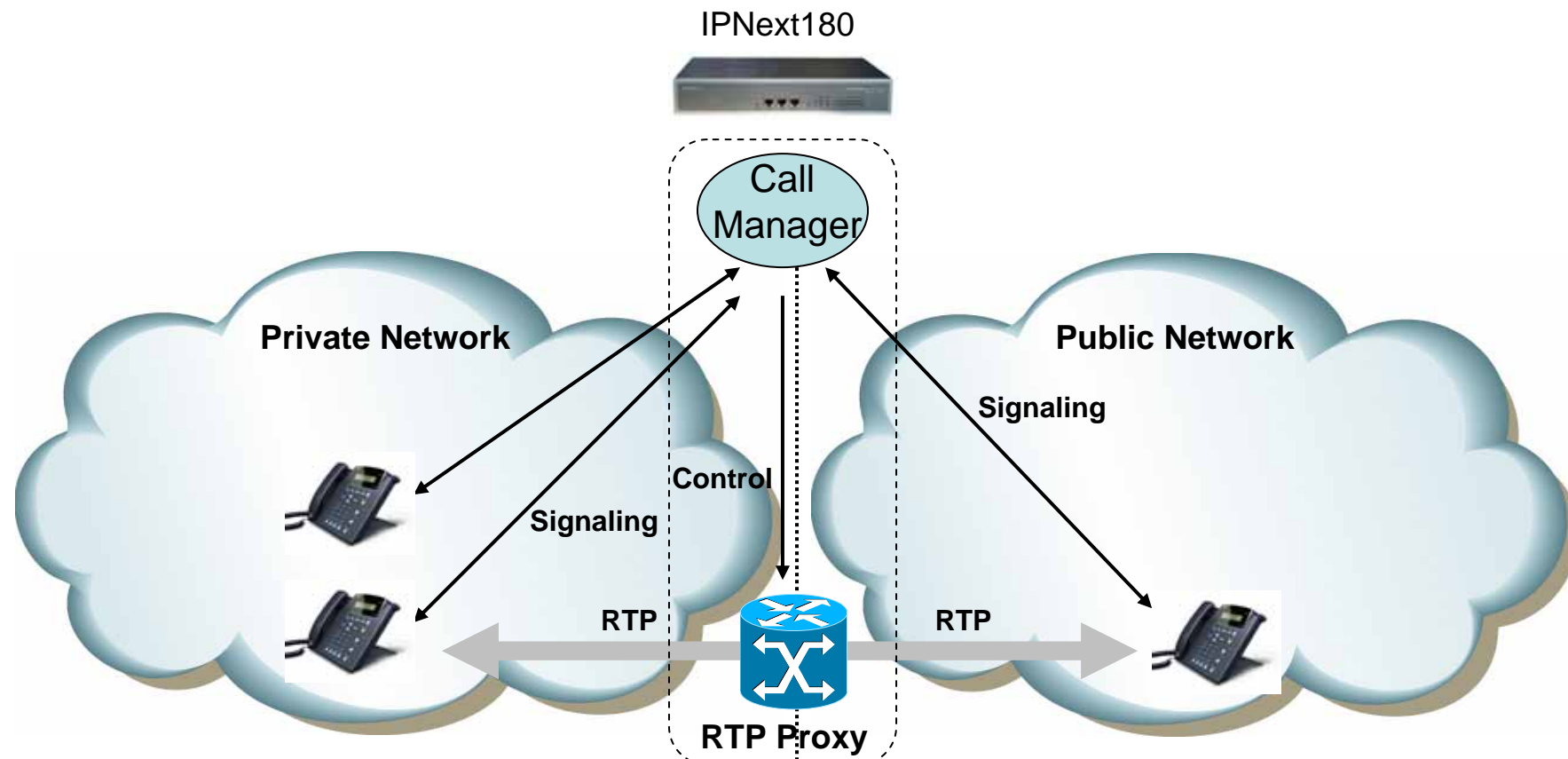

- Located between public and private network
- Call manager and RTP proxy has public and private address
- Call manager determine that the call is internal or external

Asymmetric/Symmetric NAT

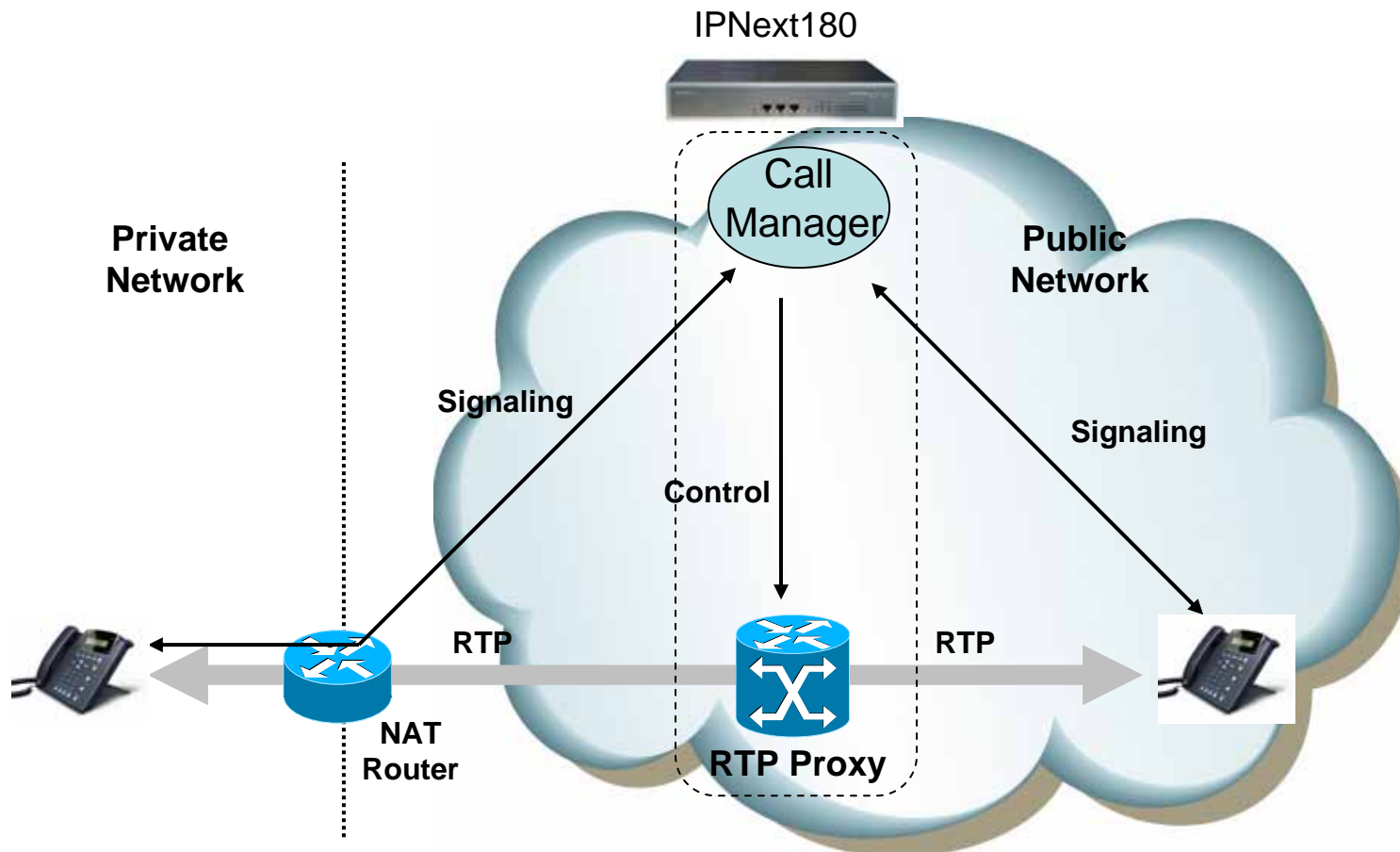

- Located in public network
- RTP Proxy has single public address
- Auto detect for asymmetric NAT via incoming RTP packet

RTP Proxy Communication between Private IP

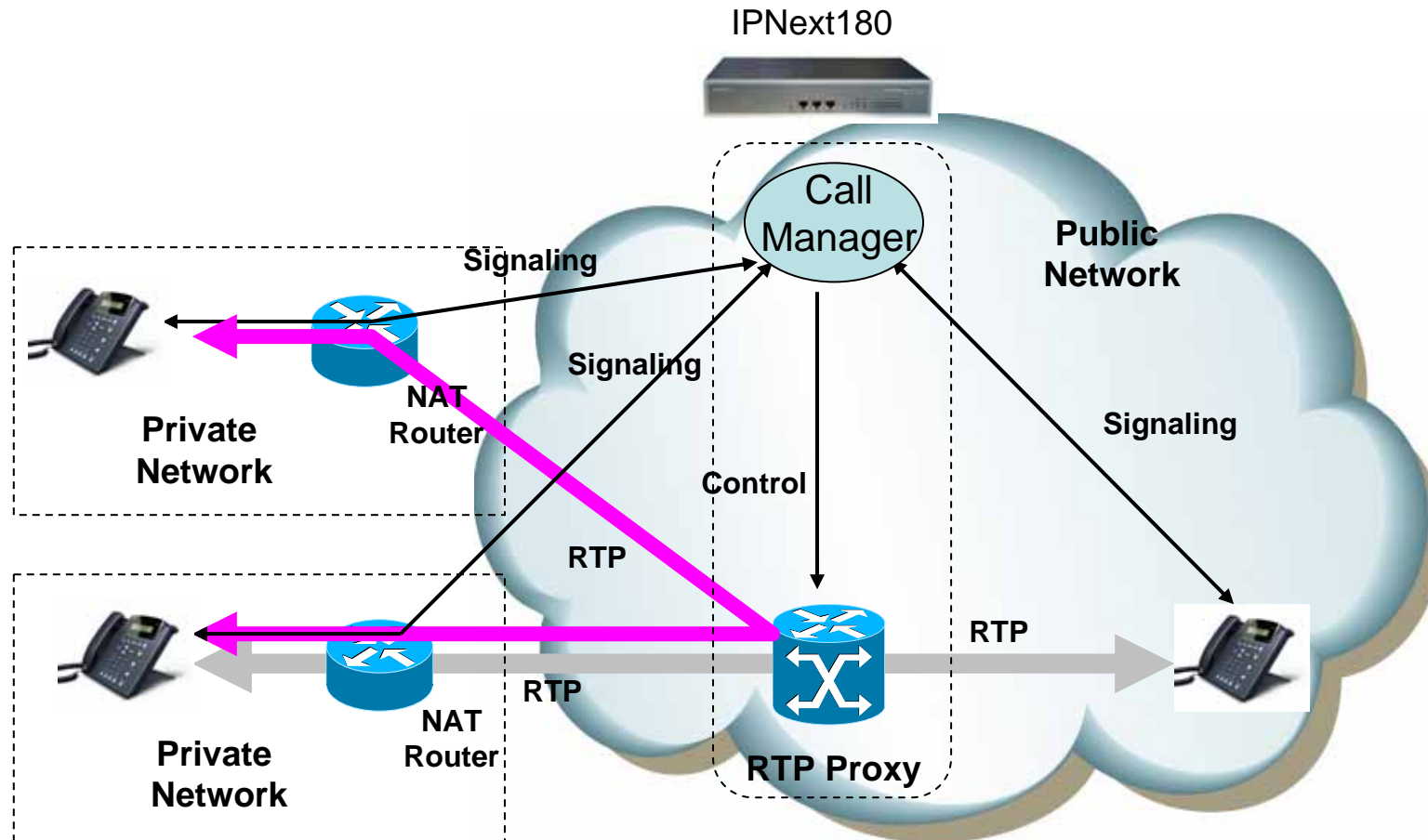

- Located in public network
- RTP Proxy has single public address
- Auto detect for asymmetric NAT via incoming RTP packet

RTP Broadcast

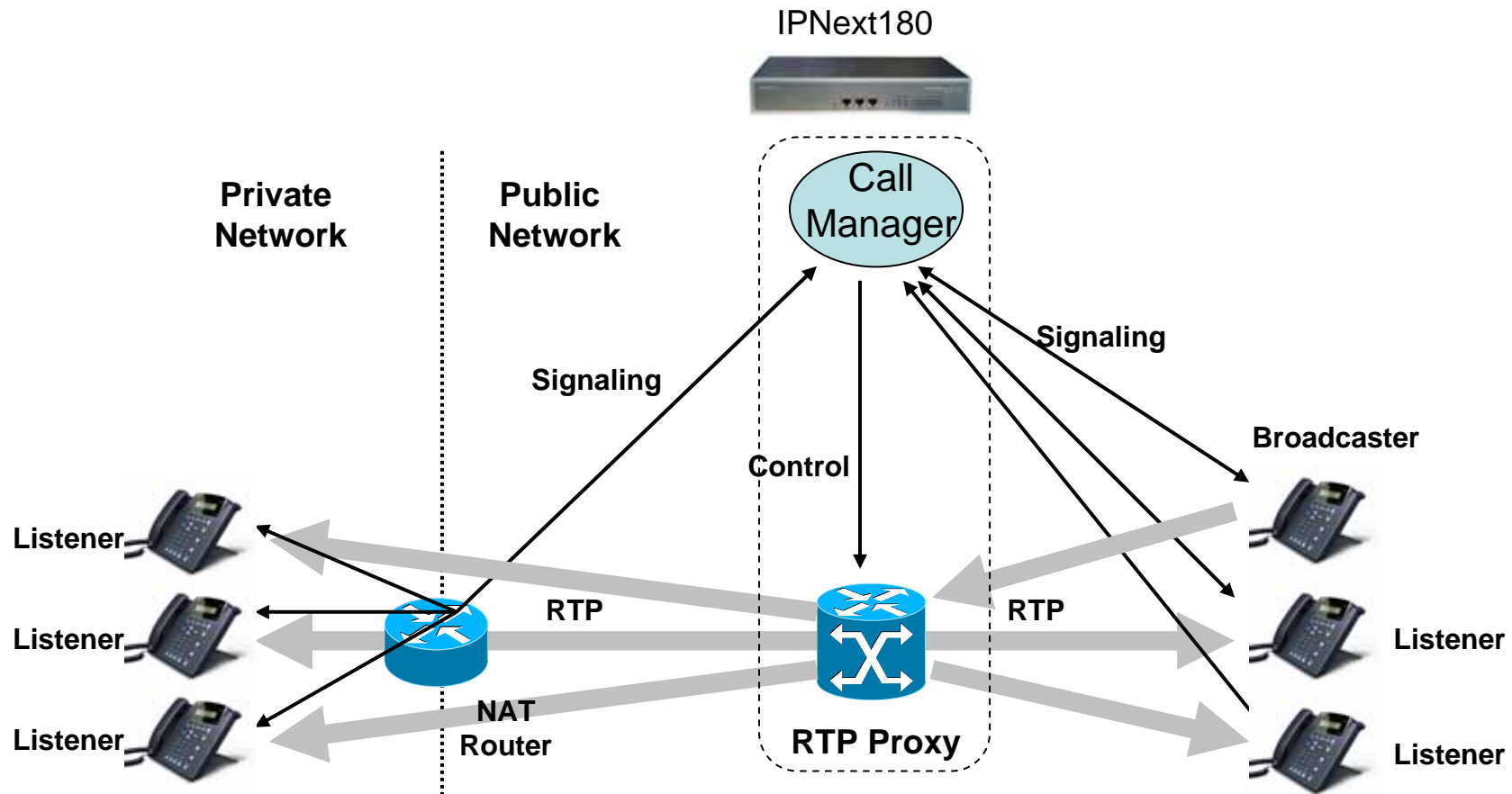

- Call Manager set the broadcaster and listener via control message
- One broadcaster and multiple listener
- RTP proxy relay for broadcaster RTP traffic
- RTP proxy never relay for listener traffic

RTP Conference

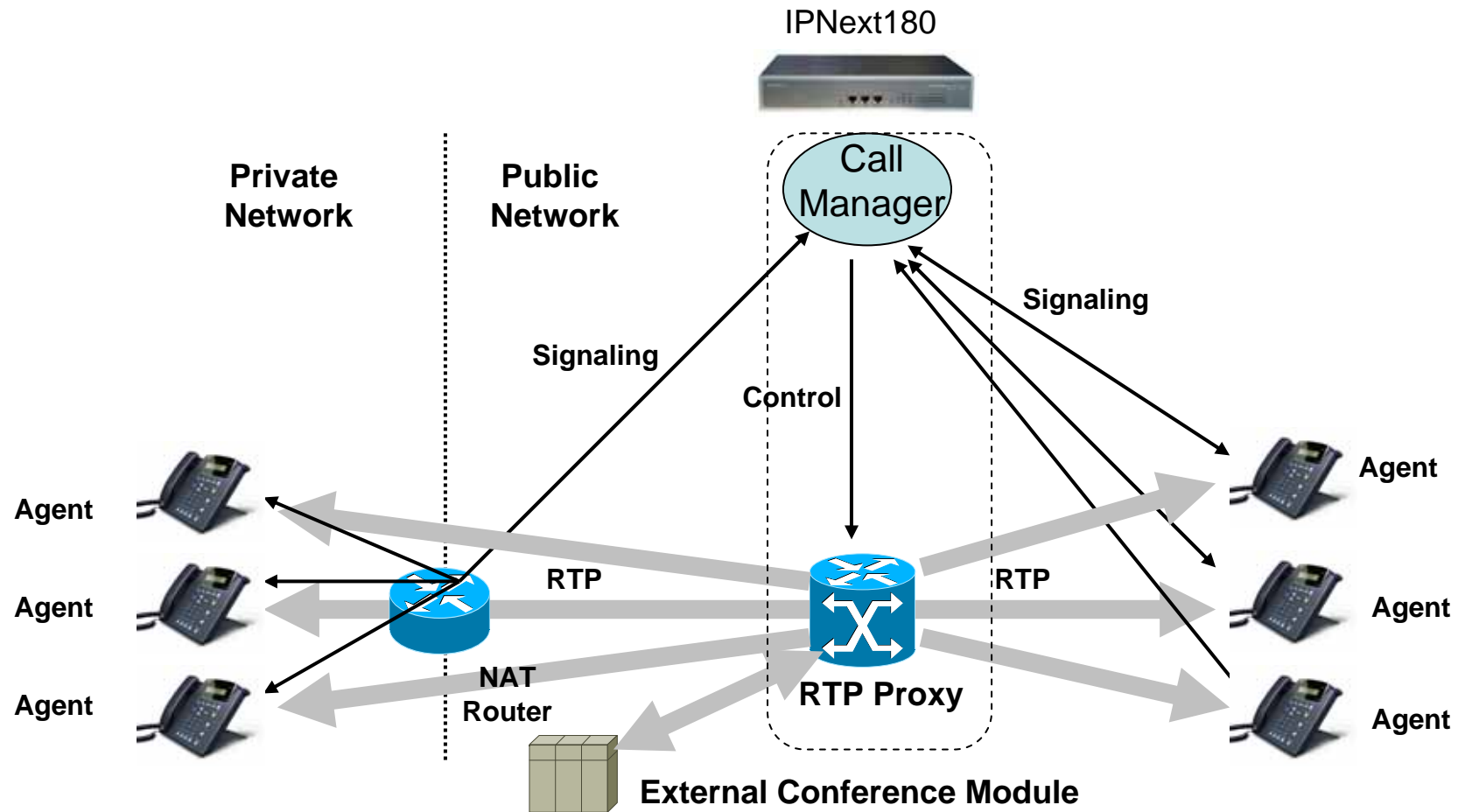

- RTP Proxy communicate with external/internal conference module (mixer)
- Conference support for private address, asymmetric NAT

IPv4/IPv6 RTP Proxy

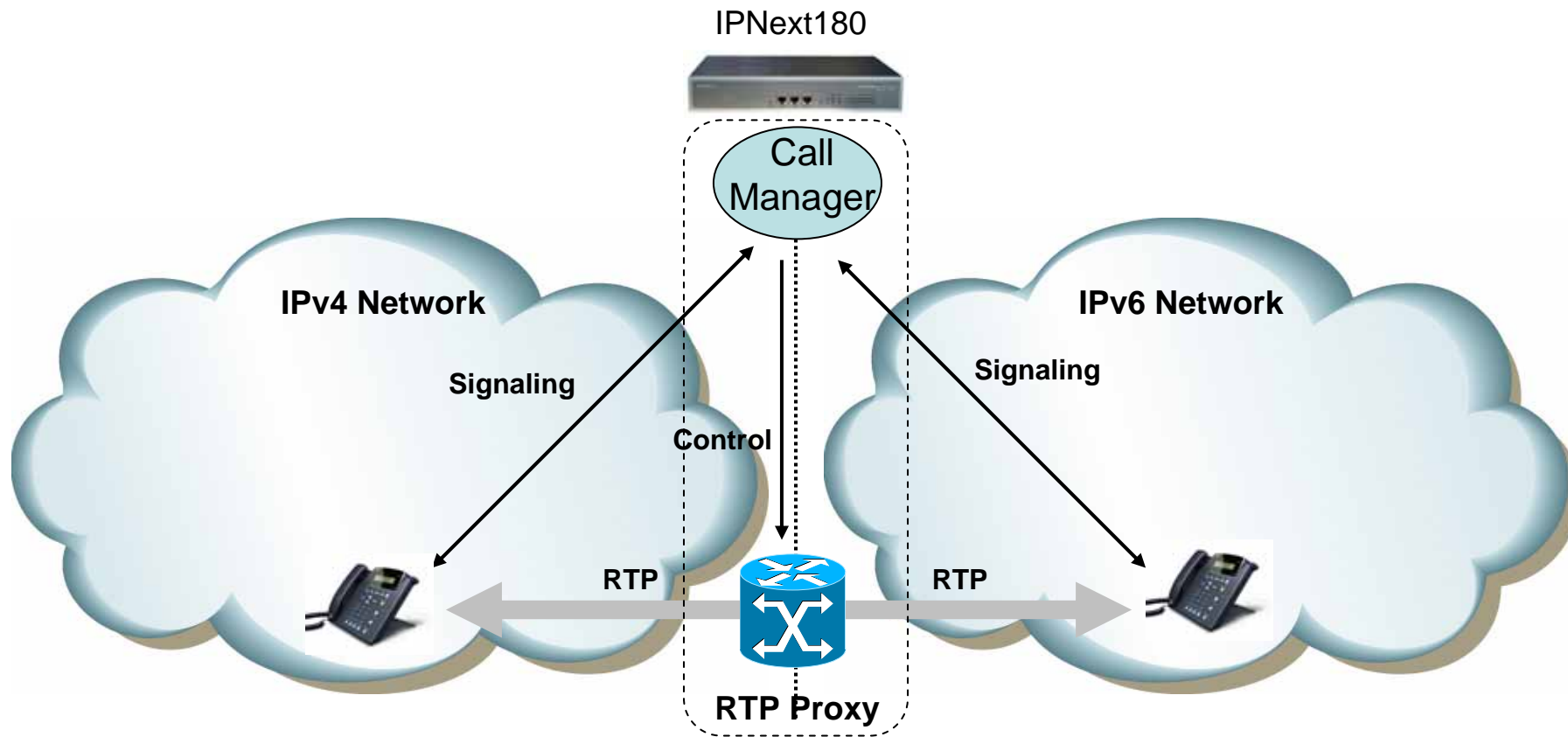

- Call manager and RTP proxy has IPv4 and IPv6 address
- Support RTP broadcasting



Signal Flow Diagram

Signal Flow Diagram (Ex: SIP)

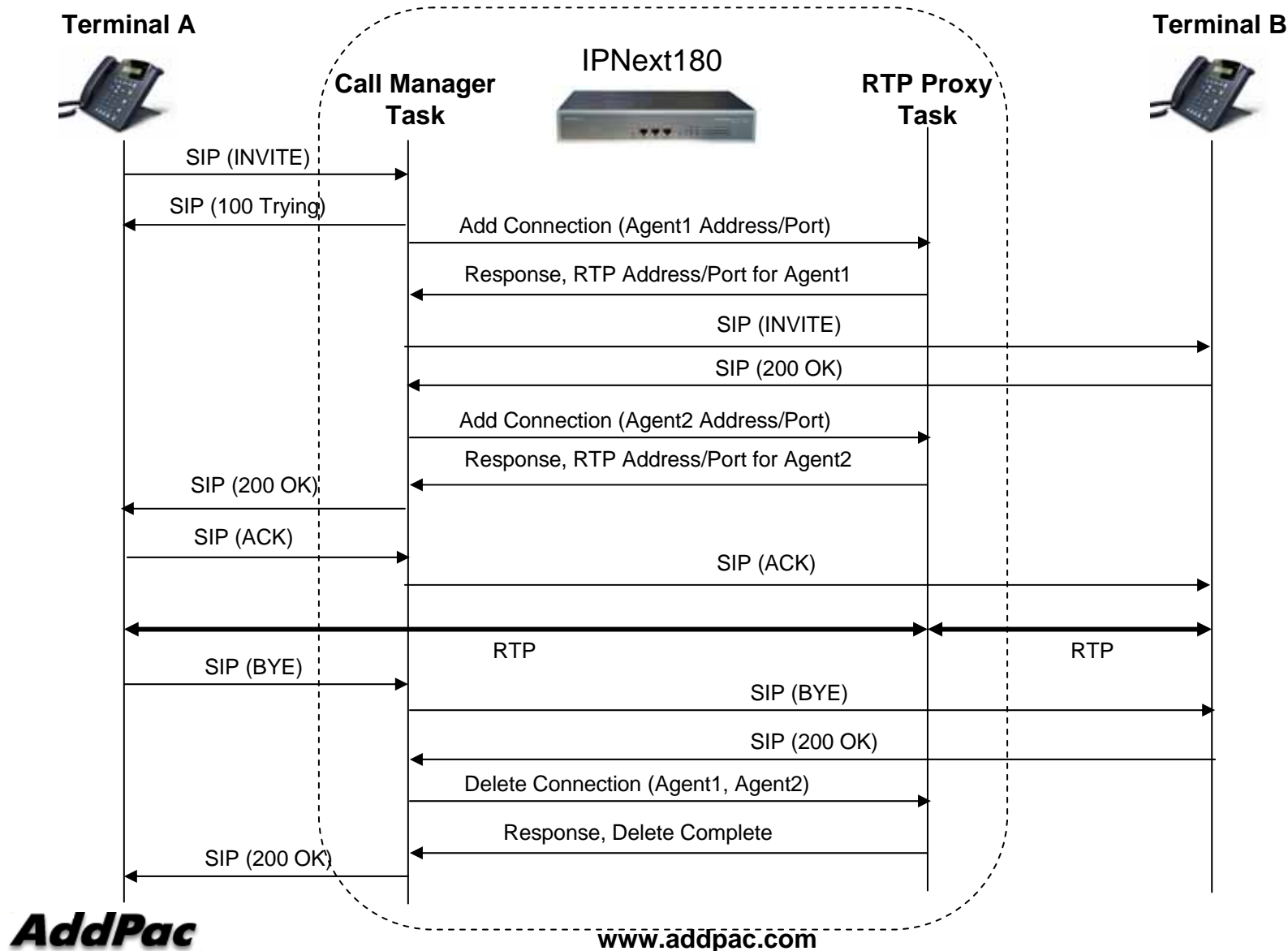

RTP Proxy Control Message

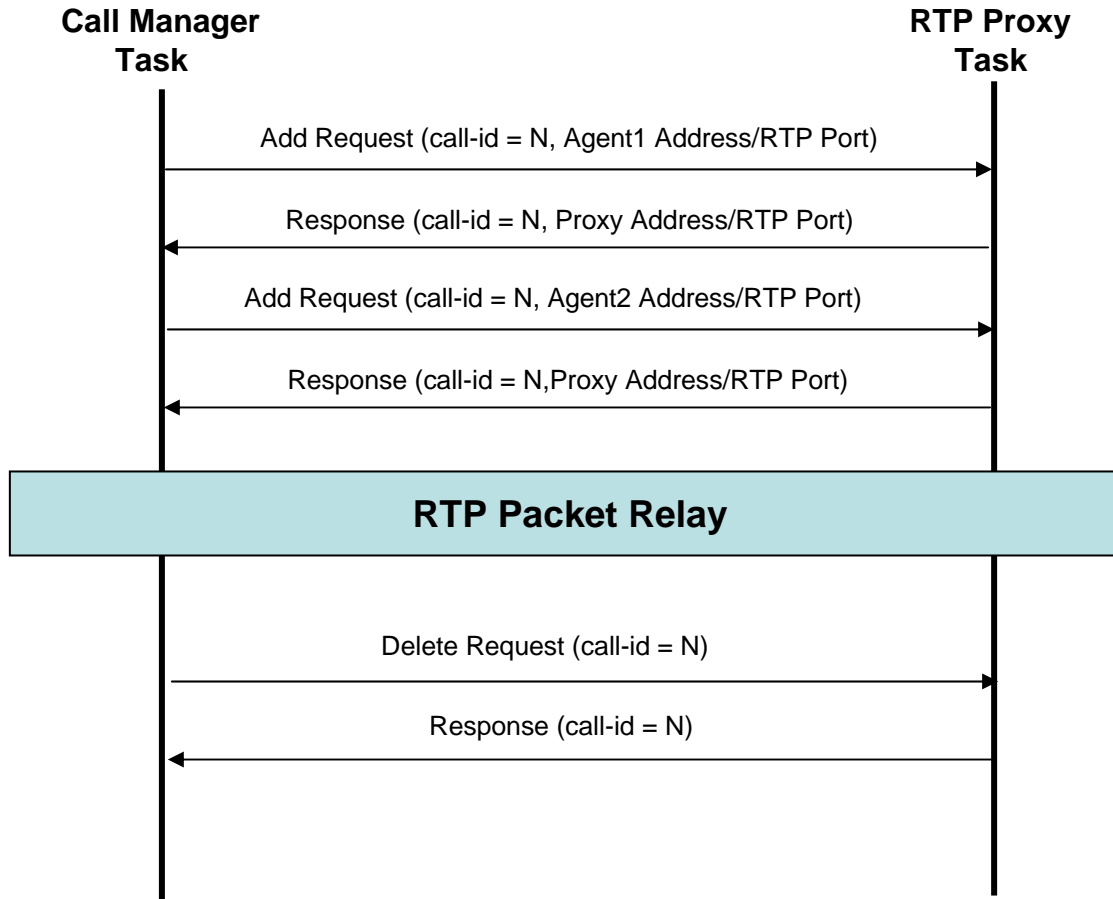



Thank you!

AddPac Technology Co., Ltd.
Sales and Marketing

Phone +82.2.568.3848 (KOREA)

FAX +82.2.568.3847 (KOREA)

E-mail sales@addpac.com